

# **INSTRUCTION MANUAL**

## **1/10TH SCALE 4WD R/ C PIVOT BALL SUSPENSION STYLE NITRO POWERED VEHICLES**

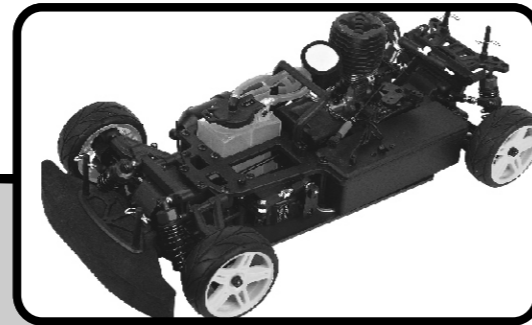

**A. On-road Car**

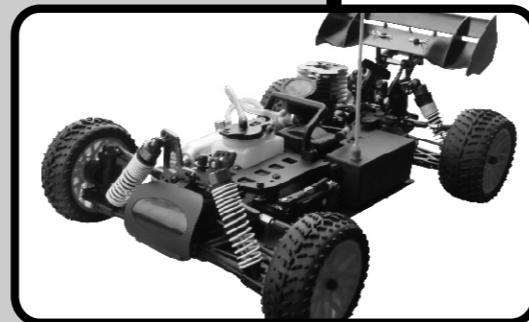

**B1. Off-road Buggy**

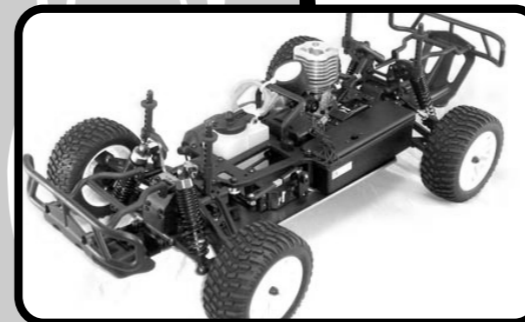

**B2. Rally Monster**

**C. Off-road Monster Truck**

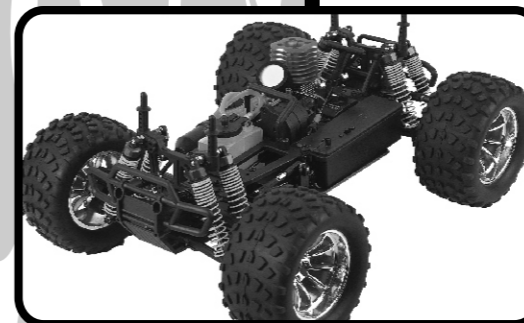

### **Notes:**

- ⇒ **The radio controlled racing models is not toy. It is suited for experienced operators.  
Read and understand the instructions carefully before operating or assembling your racing model.**
- ⇒ **Specifications are subject to change without prior notice, and actual received model may vary from the images and/or descriptions in this manual.**

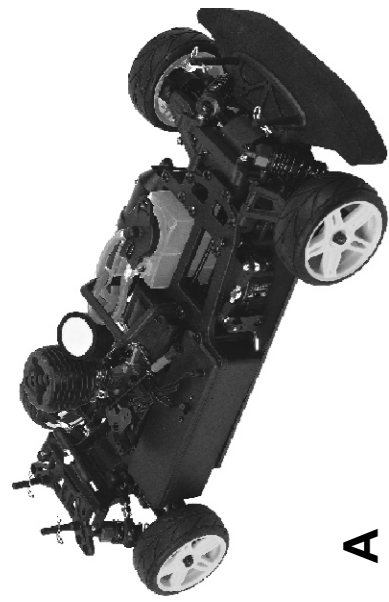

**A**

**A. 1/10th scale On-road Car**

**Features:**

1. Pivot ball suspension style
2. Extra low chassis design allows for quick on-road running
3. Large Capacity 75CC Leak Proof Fuel Tank With Overflow Pipe and Spring Loaded Fill Cover Providing Quick Re-fueling
4. Front/rear Leak proof Differential With Metal Bevel Gears
5. Lightweight Aluminum Flywheel 13.8g Provides Quick Engine Response.
6. Adjustable Oil Filled Aluminum Capped Shock Absorbers
7. Differentials With 5 Screws Providing Quick Maintenance
8. Powerful Disk Brake System With User Replaceable Pads
9. Enhanced 2.5 mm Aluminum Chassis
10. High Flow Dual Foam Element Air Filter (\*User Serviceable)
11. Fashionable on road tires and shiny wheel rims
12. High Quality Power Silencer And Regulated Fuel Tank Vent
13. High quality anti-skid on road tire

**SPECIFICATIONS:**

**Length: 360mm**    **Width: 200mm**  
**Height: 112mm**    **Wheelbase: 260mm**  
**Track: 195mm(F/R)**  
**Gear Ratio: 5.84:1(L), 8.58:1(H)**  
**Ground Clearance: 4.5mm**  
**Weight: Approx. 1665g**  
**Wheel: 65mm(Diameter), 26mm(Width)**  
**Engine: 18cpx engine recommended**

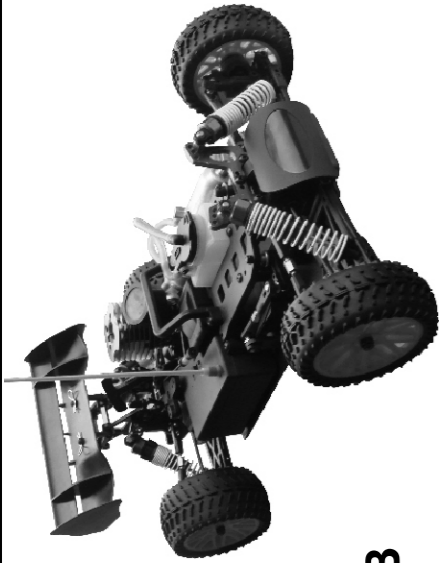

**B**

**B1. 1/10th scale Off-road Buggy**

**Features:**

1. Pivot ball suspension style
2. Large Capacity 75CC Leak Proof Fuel Tank With Overflow Pipe and Spring Loaded Fill Cover Providing Quick Re-fueling
3. Front/rear Leak proof Differential With Metal Bevel Gears
4. Lightweight Aluminum Flywheel 13.8g Provides Quick Engine Response.
5. Adjustable Oil Filled Aluminum Capped Shock Absorbers
6. Differentials With 5 Screws Providing Quick Maintenance
7. Powerful Disk Brake System With User Replaceable Pads
8. Enhanced 2.5 mm Aluminum Chassis
9. High Flow Dual Foam Element Air Filter (\*User Serviceable)
10. Fashionable Knobby off road tires and solid beautiful wheel rims as well as smart designed wing with well-cut.
11. High Quality Power Silencer And Regulated Fuel Tank Vent
12. Off road knobby tires and stylish off road wing

**SPECIFICATIONS:**

**Length: 400mm(B1) 460mm(B2)**    **Width: 250mm**  
**Height: 160mm**    **Wheelbase: 275mm**  
**Track: 185mm(F/R)**  
**Gear Ratio: 5.84:1(L), 8.58:1(H)**  
**Ground Clearance: 26mm**  
**Weight: Approx. 1780g**  
**Wheel: 86mm(Diameter), 32mm (Width-F), 40mm (Width-R)**  
**Engine: 18cpx engine recommended**



**C**

**C. 1/10th scale Monster Truck/Wecker/Army/Jeep**

**Features:**

1. Pivot ball suspension style
2. Large Capacity 75CC Leak Proof Fuel Tank With Overflow Pipe and Spring Loaded Fill Cover Providing Quick Re-fueling
3. Front/rear Leak proof Differential With Metal Bevel Gears
4. Lightweight Aluminum Flywheel 13.8g Provides Quick Engine Response.
5. Adjustable Oil Filled Aluminum Capped Shock Absorbers
6. Differentials With 5 Screws Providing Quick Maintenance
7. Powerful Disk Brake System With User Replaceable Pads
8. Enhanced 2.5 mm Aluminum Chassis
9. High Flow Dual Foam Element Air Filter (\*User Serviceable)
10. High Quality Power Silencer And Regulated Fuel Tank Vent
11. 1/10" scale off road monster tires / Smart shiny wheel rims (Chrome plated wheel rims are in optional use)

**SPECIFICATIONS:**

**Length: 420(mm)**    **Width: 330(mm)**  
**Height: 185(mm)**    **Wheelbase: 275(mm)**  
**Track(F/R): 150(mm)**    **Gear Ratio: 13.34:1**  
**Ground Clearance: 30(mm)**    **Weight: 2100g**  
**Diameter of wheel: 120\*60(mm)**  
**Engine: 18cpx**

**B2. 1/10th scale Rally Monster**

**SPECIFICATIONS:**

**Length: 460mm**  
**Width: 250mm**  
**Height: 160mm**  
**Wheelbase: 275mm**  
**Track: 185mm(F/R)**  
**Gear Ratio: 5.84:1(H), 8.58:1(L)**  
**Ground Clearance: 26mm**  
**Wheel Diameter: 86mm**  
**Wheel Width: 32mm (Front), 40mm (Rear)**  
**Engine Level: 16/18cpx**

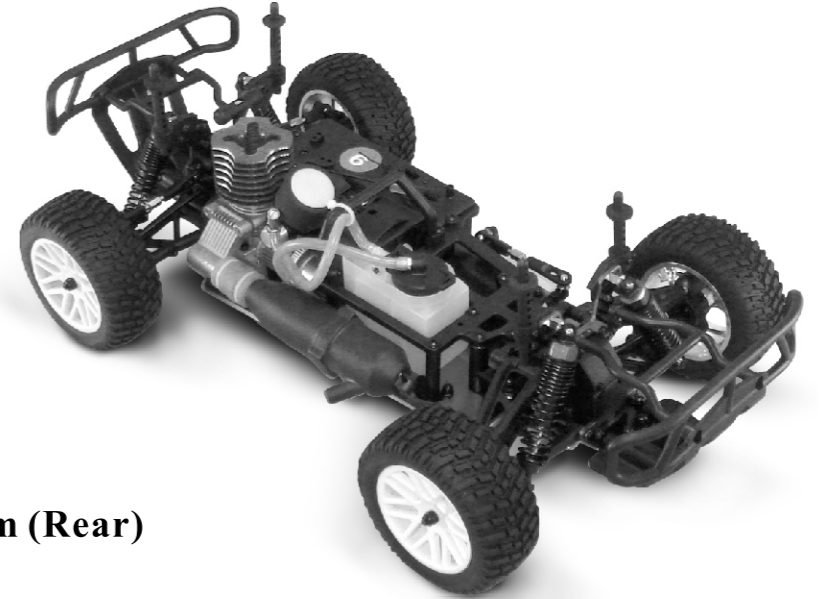

**Before assembling or operating your model...**

Carefully read and understand all instructions before operating the vehicle. Correct adjustment of high speed needle and idle adjustment are required before operating your vehicle. Refer to carburetor adjustments before operating vehicle. The following items(not included unless specified) are required to operate your vehicle and are available from your model dealer or the local hobby shop.

**Essential Items For Running Your Model**

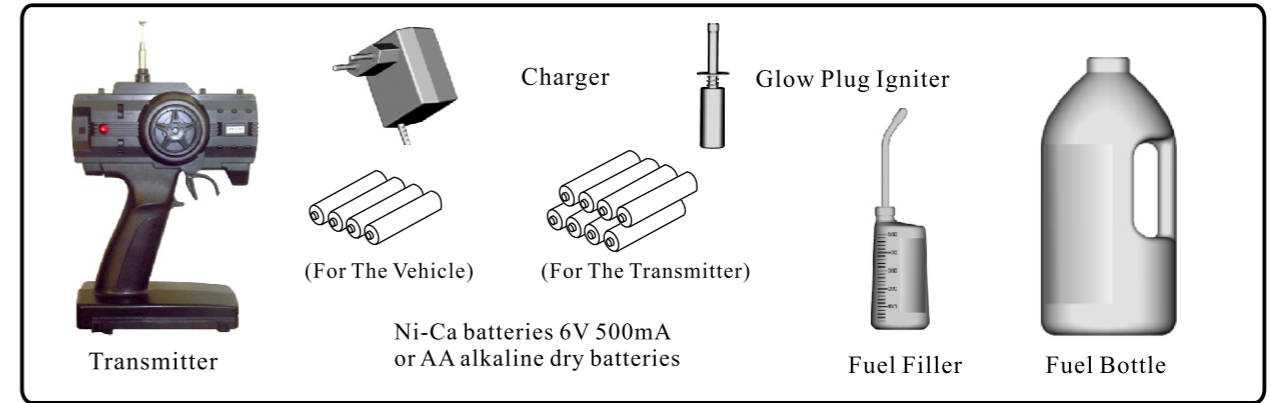

**Tools For Assembling Your Model**

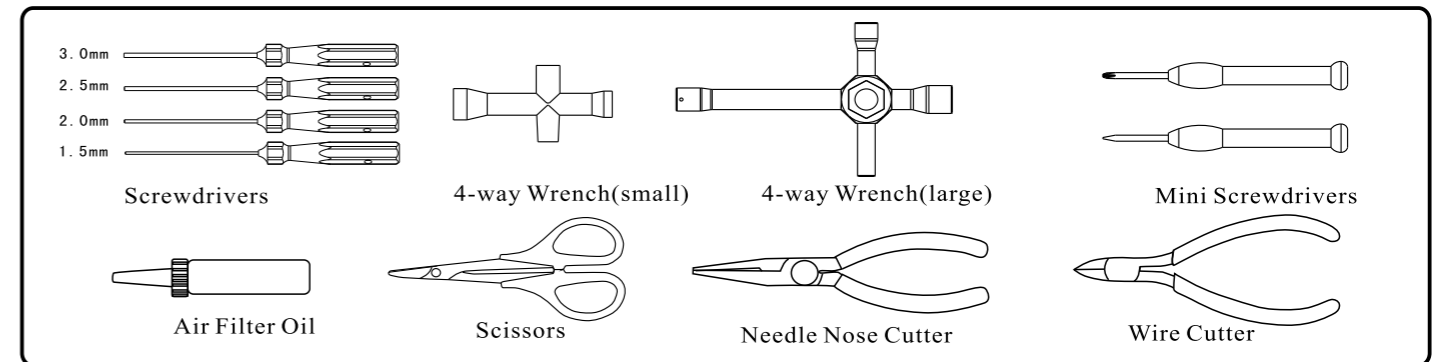

# Use of transmitter to control your vehicle...

## Install the batteries in the transmitter

Insert the eight "AA" batteries into the battery compartment on the bottom of the transmitter.

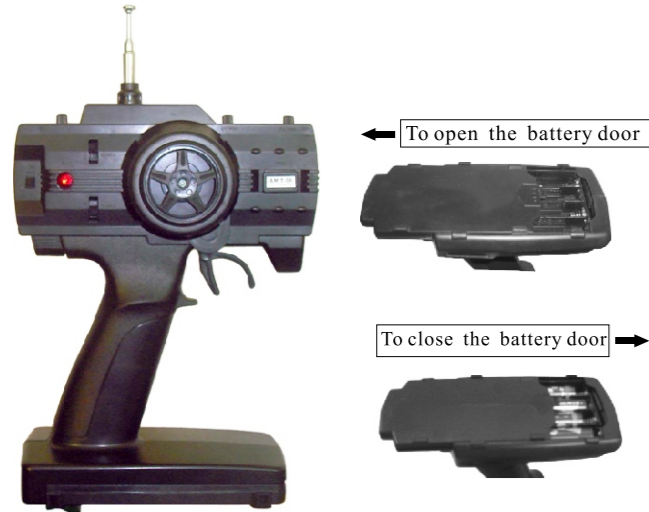

### Battery Precautions:

1. In order to keep better performance, we strongly recommend you to use the 1.5V alkaline batteries instead of the 1.2 V chargeable batteries.
2. The batteries may leak in the event that they are installed with wrong polarities.
3. Do not use batteries of different types.
4. Do not mix old and new batteries.
5. Do not leave the batteries if not in use for long periods.

### The function switches on the transmitter

- |                     |                            |
|---------------------|----------------------------|
| 1. Antenna          | 6. Working Indicator       |
| 2. Steering Trim    | 7. Power Switch            |
| 3. Throttle Trim    | 8. Steering Reverse Switch |
| 4. Crystal          | 9. Throttle Reverse Switch |
| 5. Throttle Trigger | 10. Steering Wheel         |

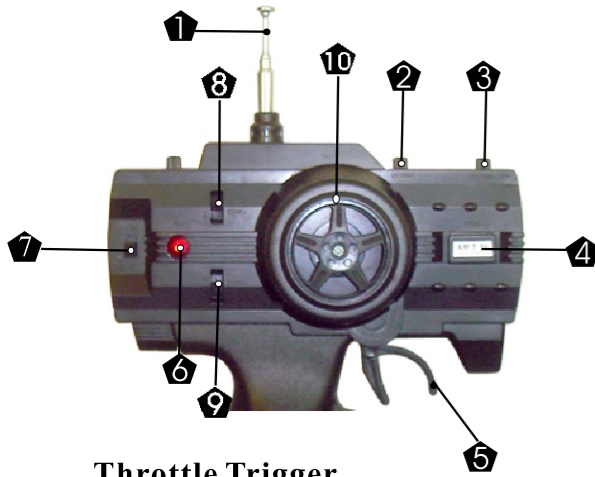

### Throttle Trigger

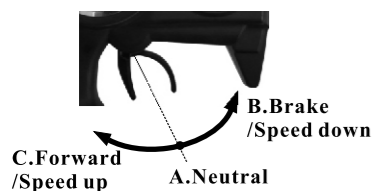

1. Push the trigger forwards to allow the vehicle to speed down to brake.
2. Pull the trigger backwards to allow the vehicle to go forward and speed up.

### Steering Wheel

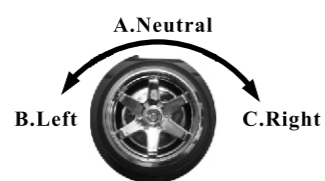

Turn the steering wheel to the left or right to let the vehicle turn left or right.

### Throttle/Steering Trim

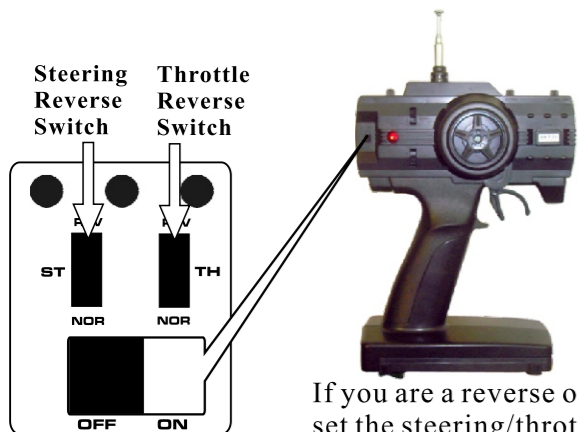
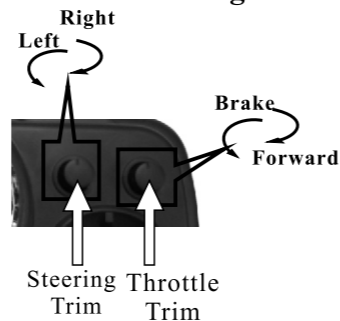

If you are a reverse operator, set the steering/throttle switch to REV. Position first.

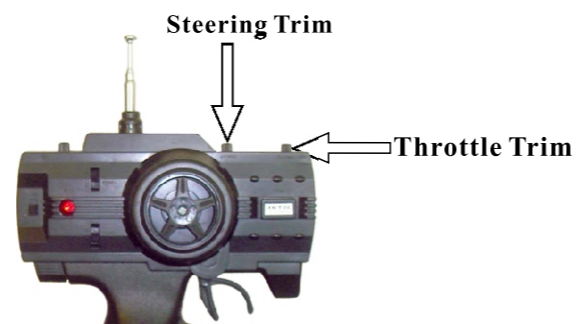

Throttle Trim is used to slightly trim the throttle servo when the trigger is at Neutral position.

## 2-Channel Radio System

Please read the following instructions before operating your vehicle.

Servos must be centered before operating. Performance of vehicle will be affected if this procedure is not completed.

To perform initial servo adjustment, rotate both trim controls on transmitter to center position.

Power on the transmitter then power on the receiver (switch is located on top cover )

Servos are now centered, linkage adjustment can now be completed.

Steering linkage: With trim knob at center position front wheels should point in a straight ahead .

If wheels point in either direction remove control horn from servo and center the wheels

(along drive-line axis) replace control horn and observe corrections and re-adjust if necessary.

Trim knob and servo are now centered, fine tuning of steering control can now be adjusted with steering trim knob on transmitter.

Throttle/Brake linkage: With trim knob at center position, throttle will be closed. If carburetor linkage is open at center position remove control horn from servo and center the linkage, replace control horn and observe corrections and re-adjust if necessary.

Trim knob and servo are now centered, fine tuning of throttle control can now be adjusted with steering trim knob on transmitter.

Brake adjustment is performed via the thumb wheel on the end of the throttle linkage, brakes should not be applied at neutral position (vehicle must free-wheel when trigger is released)

Before operating your new engine please perform required break in procedure otherwise performance and durability of engine shall be compromised.

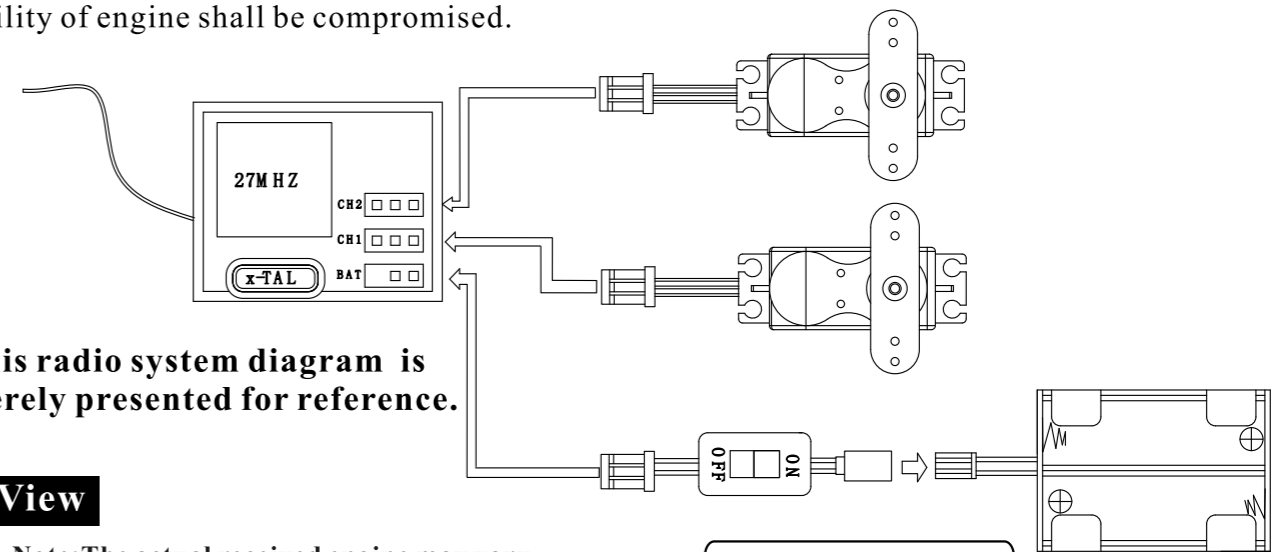

## Engine View

Note: The actual received engine may vary from this image. The image is presented for your reference only.

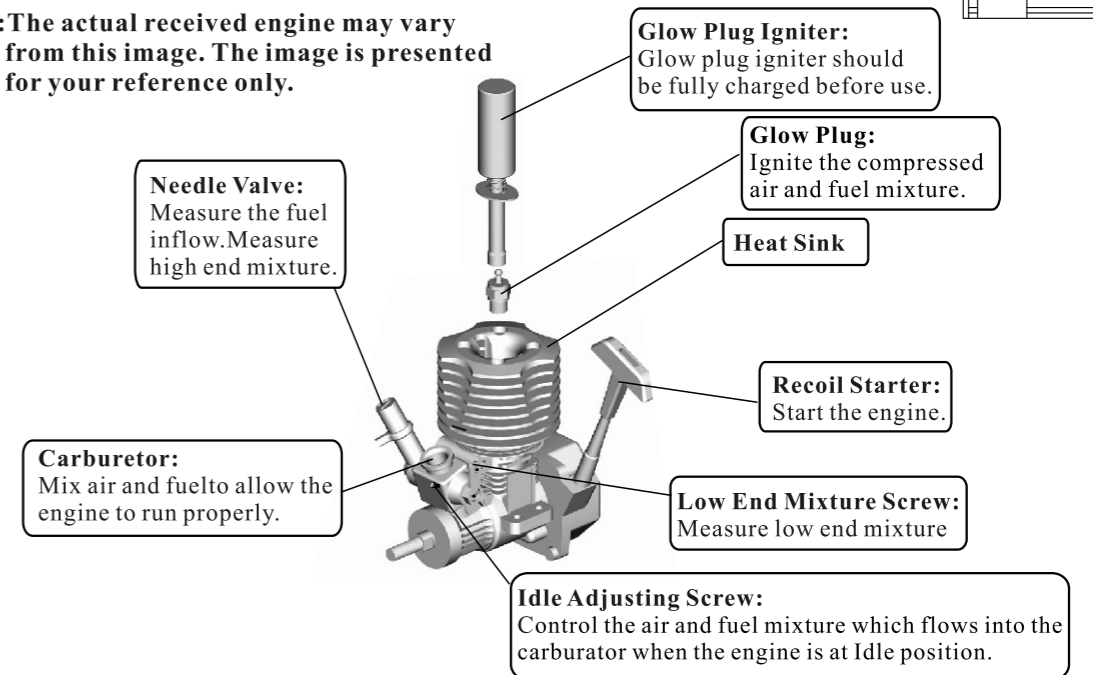

Note: The engine includes many high-precision parts. The original performance may be reduced due to wrong operations or assembly and disassembly.

## Engine Break In

Many hobby type glow engines require a break in period to provide final adjustment of internal parts after manufacturing. This procedure is required and must be completed by you/the user. To prevent excessive initial wear on internal engine parts a rich air/glow fuel mixture is required to perform your engine break in.

### Very important procedure must be followed !!

Break-in period 2 and 1/2 turns from full closed position (4-5 tanks of 10-15% nitro/20% oil content) must be used to perform break in, do not run engine full throttle for long periods during break-in.

Once break-in has been performed lean out engine to best performance (2 turns to 1 and 1/2 turns from full closed position) you must always observe a trace amount of oil smoke from tune-pipe, if you do not see any smoke stop immediately and re-adjust needle valve till smoke is observed.

Always perform needle valve adjustment first, and then perform idle adjustment on a warmed-up engine. Environment conditions may require further adjustments.

Clean-out engine and exhaust system by applying high throttle (3/4 throttle) for 2 seconds after adjustment to permit effectiveness of adjustment to be observed.

We highly recommend replacing the engine " Glow Plug "(part # 70117) after you have completed the break-in.

It is of normal occurrence during the break-in that miniscule particles of metal adhere to the glow element. The particles of metal isolate the glow element and affect overall engine performance.

You may also be required to replace your glow plug during your break in procedure.

Normal nitro content: Once break-in has been performed 20% - 35%

Lubrication: We highly recommend a Premium glow fuel with a Synthetic/Castor blend of a minimum of 16% and maximum of 20% combined lubricant content.

## Engine Adjustment/Maintenance

### Engine Adjustment

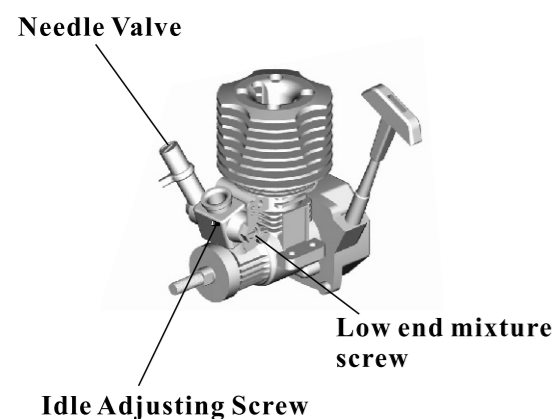

#### 1. Needle Valve Adjustment

A. Start the engine to run your car

B. Keep an eye on the current running speed when the car is running straight with the throttle control set to High. The speed will go up when you screw in the needle valve at an angle of 10 or 20 degrees.

C. When continuing to screw the needle valve further in, the engine will become overheated and subject to damage. If it is the case, immediately unscrew the needle valve at an angle of 10 or 20 degrees to allow the engine to return to normal running.

#### Acceleration from idle position.

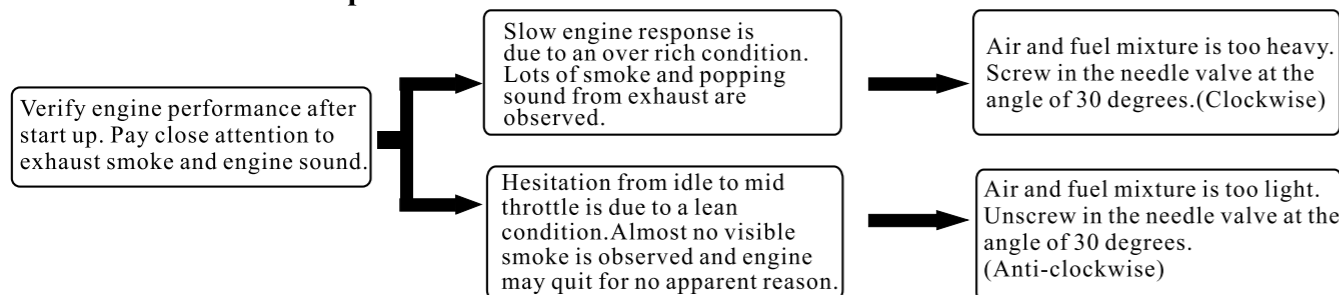

#### 2. Low end Adjusting Screw

Low end adjusting screw is used to trim the air and fuel mixture to flow into the carburator.

#### 3. Idle Adjusting Screw

Idle adjusting screw is used to control the air and fuel mixture which flows into the carburator when the engine is at Idle position.

## Engine Maintenance

1. Empty fuel tank and fuel lines before storing your vehicle.
2. Use premium " After Run Oil" this lubricant is utilised for storing of your engine  
Observe manufacturers instructions.
3. Remove all dirt and debris from vehicle with small brush (tooth brush) and/or with compressed air (observe proper personal security when operating air equipment)
4. Inspect and adjust all moving parts for excessive play, if adjustment cannot remove all excessive play observe part integrity and replace if required.
5. Correct lubrication of all bearings and moving mechanism is necessary for proper operation.
6. Disconnect and inspect batteries for leakage, recharge as required, do not store vehicle with batteries in unit for prolonged periods.
7. Operating radio controlled devices in wet/damp conditions is not suggested, vehicle may lose traction abruptly, and vehicle may be subject to water penetration in receiver compartment or in servos and loss of control of vehicle is imminent.

## ENGINE START TROUBLESHOOTING

If the engine fails to be started after the normal procedures are performed, please take it seriously and get down to the following:

- Verify that the approx. 0.5cc of fuel has flowed into the engine. The fuel that flowed into the engine should not be too heavy. Otherwise, the engine will become flooded and unable to function.
- Verify that a full-charged glow plug igniter is used. (If the glow plug can be excited and its pin subjects to turn red, it indicates that the glow plug igniter is of enough power. Please immediately charge it if necessary)

If the primed engine is still unable to be started by a full-charged glow plug igniter, you should perform the following procedures.

(The needle valve and/or the low end mixture screw had been properly calibrated at factory. However, you can perform some calibrations on them if necessary.)

1. Use the screwdriver to turn the needle valve and low end mixture screw tightly (clockwise), then unscrew them approx. 3 turns (anti-clockwise) to perform the correct calibration.  
Note: Some hobby type glow engines have no the low end mixture screw. If it is the case, you are only required to unscrew the needle valve.
2. Ensure there is no wrong with fuel line and fuel route.
3. Before starting the engine, verify the glow plug igniter is of enough power and the good glow plug is used.
4. Use your fingers or a dry cloth to stifle the exhaust vent while pulling the recoil starter cord 5-6 times. These actions will allow the fuel to flow into the engine.  
(Note: Do not allow your fingers and body to touch the overheated engine and exhaust vent after the engine is started. Failure to do so will cause severe burns to your body)
5. Use the glow plug igniter to excite the engine while pulling the recoil starter cord several times until the engine start is observed.

## Troubleshooting no-start condition and engine performance.

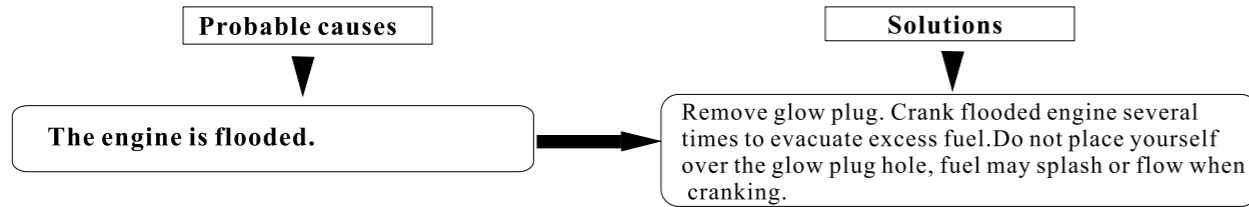

## Engine can be cranked but will not start.

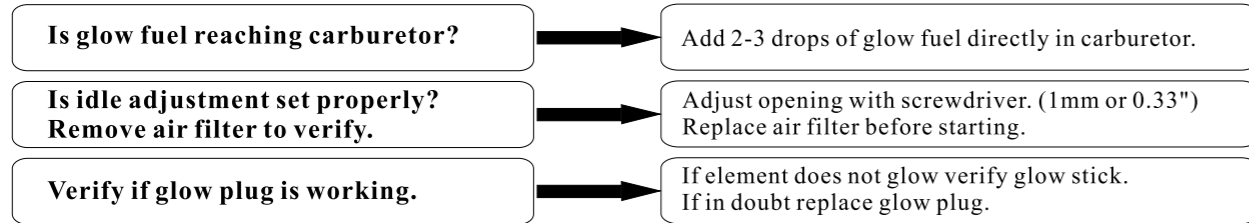

## Miscellaneous

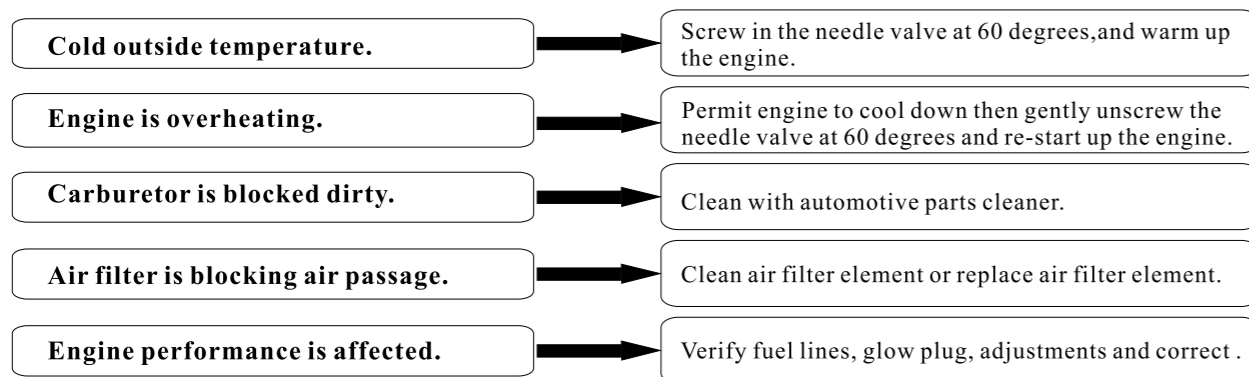

## Troubleshooting List

ISSUES	REASONS	SOLUTIONS
<b>THE ENGINE FAILS TO START.</b>	<ol style="list-style-type: none"> <li>1. The fuel tank is empty or the carburetor is not primed properly.</li> <li>2. The glow plug is bad or the batteries are dead.</li> <li>3. The fuel lines, the air filter, or the muffler is clogged.</li> <li>4. The engine is flooded.</li> <li>5. The carburetor is not adjusted properly.</li> <li>6. The servo linkage is not adjusted properly.</li> </ol>	<ol style="list-style-type: none"> <li>1. Fill the fuel tank up or prime the throttle.</li> <li>2. Replace the glow plug or charge the batteries.</li> <li>3. Clean or replace the clogged part(s).</li> <li>4. Remove the glow plug and discharge fuel.</li> <li>5. Set the Needle Valve/Low End Mixture Screw and the Idle Adjusting Screw to the Original position.</li> <li>6. Set the servo to Neutral then re-adjust it.</li> </ol>
<b>THE ENGINE CAN START BUT STALL IMMEDIATELY.</b>	<ol style="list-style-type: none"> <li>1. The fuel tank is empty.</li> <li>2. The fuel lines, the air filter, or the muffler is clogged.</li> <li>3. The carburetor is not adjusted properly.</li> <li>4. The engine is flooded.</li> </ol>	<ol style="list-style-type: none"> <li>1. Fill up the fuel tank.</li> <li>2. Clean or replace the clogged part(s).</li> <li>3. Re-adjust Idle Adjusting Screw and Needle Valve/Low End Mixture Screw.</li> <li>4. Allow the engine to thoroughly cool down and turn the Needle Valve open at the angle of 30 degrees.</li> </ol>
<b>POOR REACTION RESPONSE ON THE ENGINE.</b>	<ol style="list-style-type: none"> <li>1. The carburetor is not adjusted properly.</li> <li>2. Low fuel pressure level was found on the muffler.</li> </ol>	<ol style="list-style-type: none"> <li>1. Re-adjust Needle Valve/Low End Mixture Screw.</li> <li>2. Install the pressure line from the muffler to the fuel tank correctly.</li> </ol>
<b>THE VEHICLE BECOMES DIFFICULT TO CONTROL.</b>	<ol style="list-style-type: none"> <li>1. The batteries on the transmitter/receiver are weak.</li> <li>2. Radio antenna performs bad receptions.</li> <li>3. The servo linkage is not adjusted properly.</li> </ol>	<ol style="list-style-type: none"> <li>1. Replace or charge the batteries.</li> <li>2. Extend the transmitter antenna fully to obtain better receptions.</li> <li>3. Set the servo to Neutral then re-adjust it.</li> </ol>

## 18 CXP ENGINE DIAGRAM

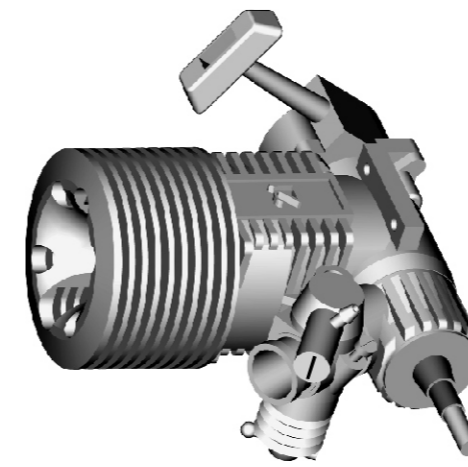

- R001-Glow Plug
- R002-Screw 4P
- R003-Cylinder Head
- R004-Gasket
- R005-Cylinder Piston
- R006-Piston Pin
- R007-Joint Lever
- R008-Carburetor Assembly
- R009-Nut
- R010-Small Flywheel
- R011-Roller Bearing(Front)
- R012-Engine Main Body
- R013-Carburetor Post
- R014-Roller Bearing(Rear)
- R015-Crank shaft
- R016-Clutch Rolling Set
- R017-Gasket for Rear Housing
- R018-Rear Housing
- R019-Screw 4P
- R020-Pull Start Lever
- R021-Screw 4P

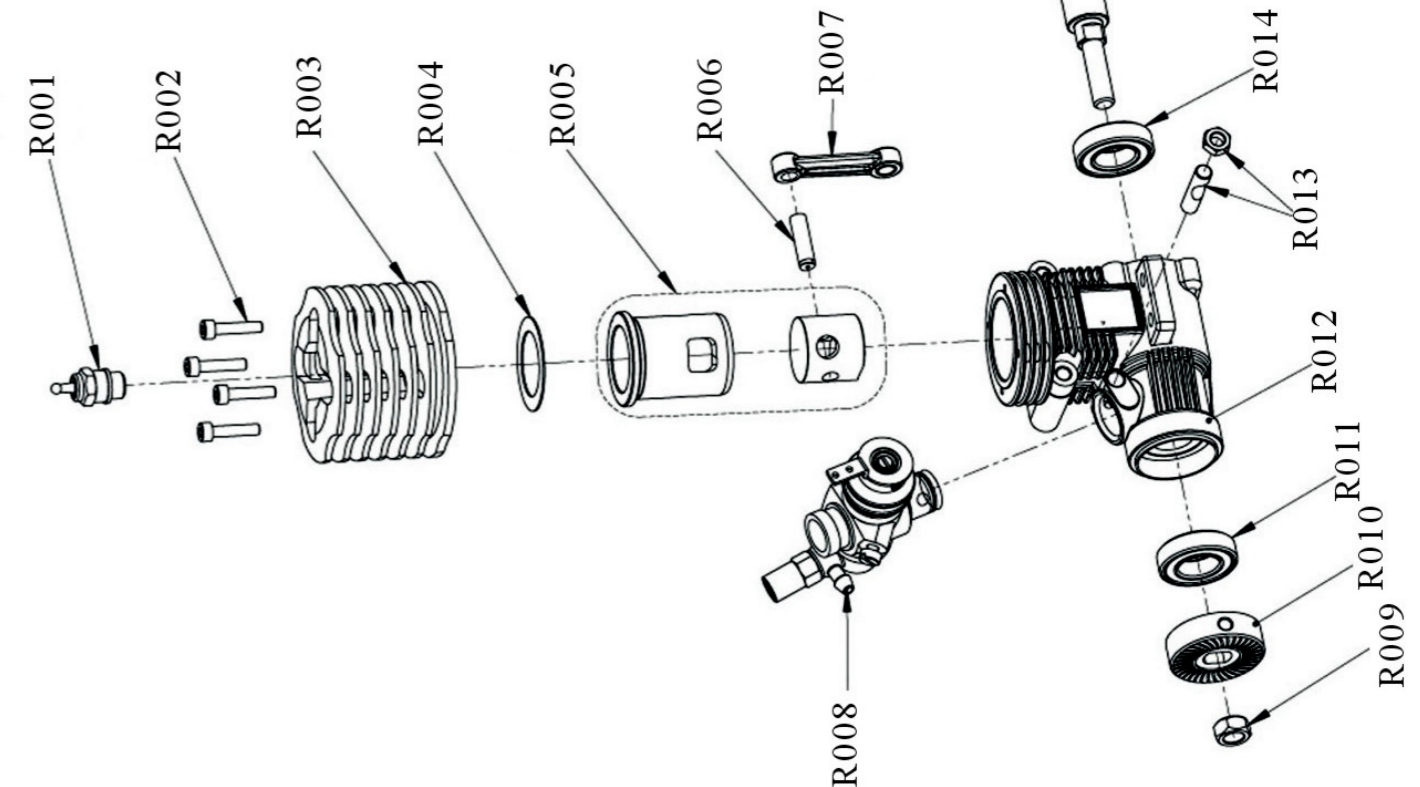

# Assembly Diagram for 1/10th scale on-road car(A)

## Front Suspension (On-road Car)

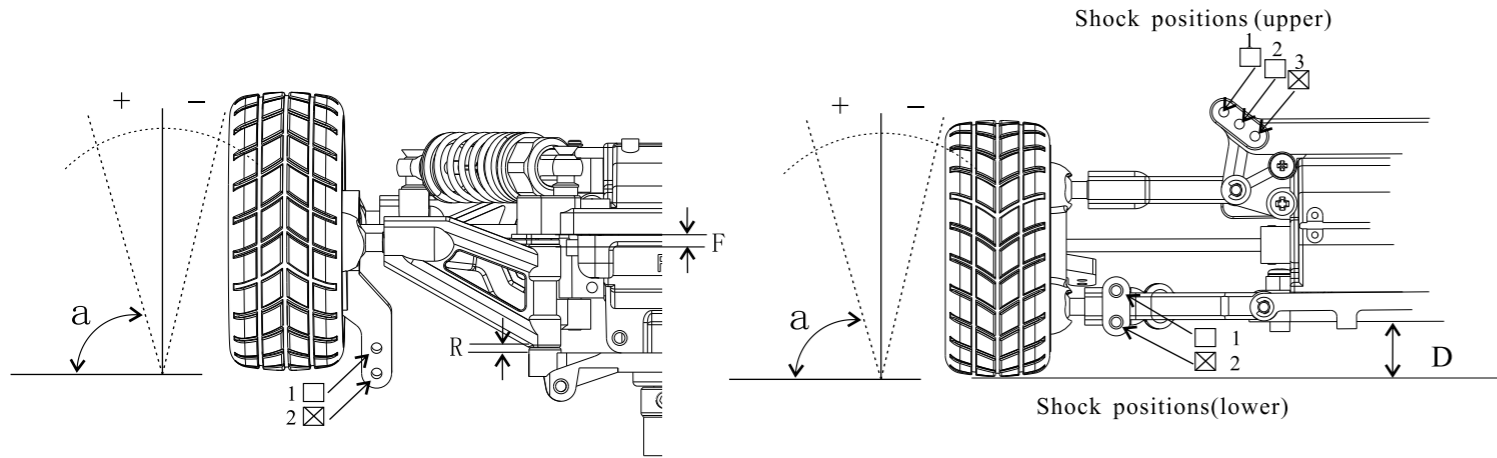

Front Adjust Ring (F) 2.0 mm

Rear Adjust Ring (R) 0 mm

Camber angle (a) -1°

Camber angle (a) -1°

Ground Clearance (D) 9.5 mm

## Rear Suspension (On-road Car)

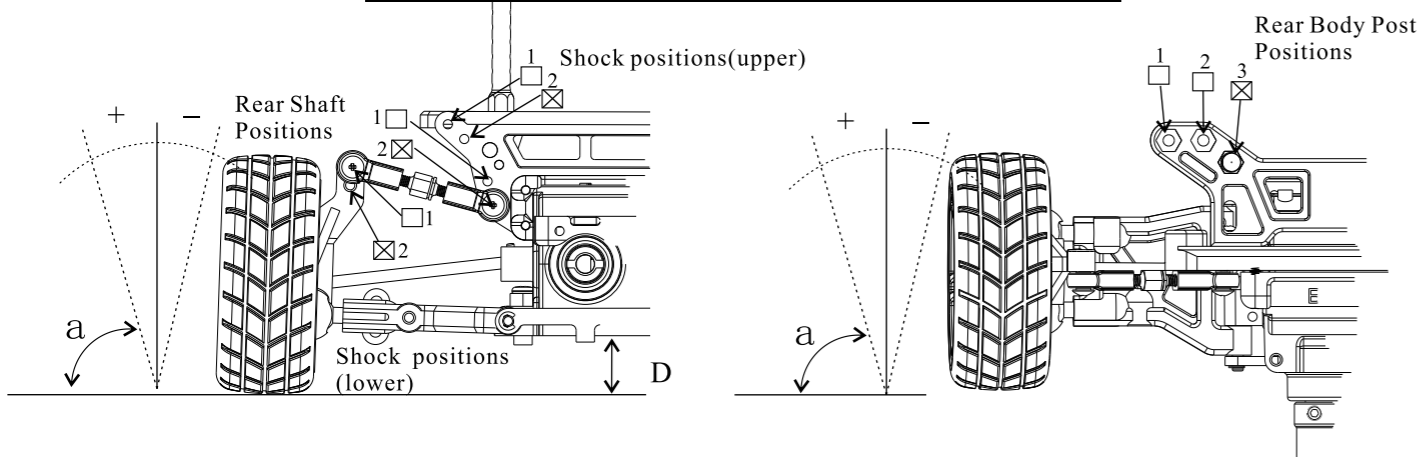

Camber angle (a) -2°

Ground Clearance (D) 8.5 mm

Camber angle (a) +2.5°

## Steering System (On-road Car)

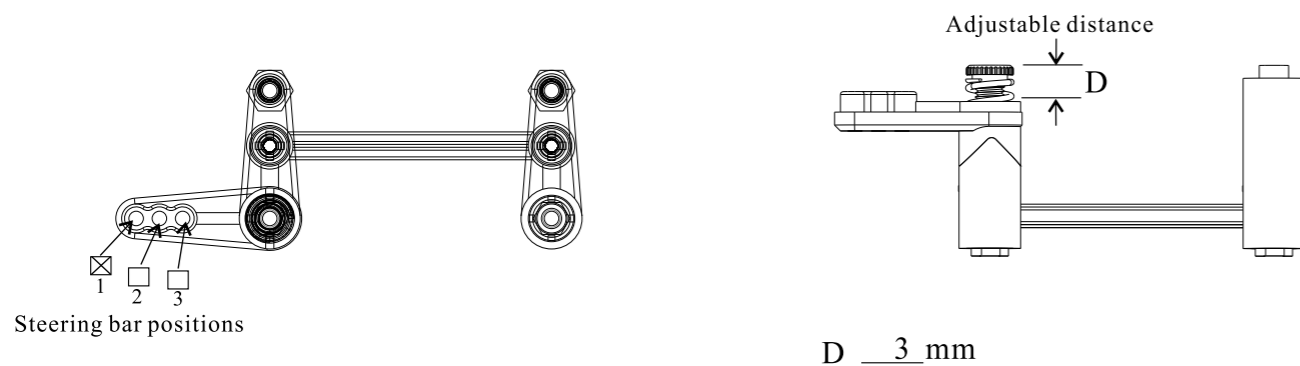

D 3 mm

# Assembly Diagram for 1/10th scale off-road buggy(B)

## Front Suspension (Off-road Buggy)

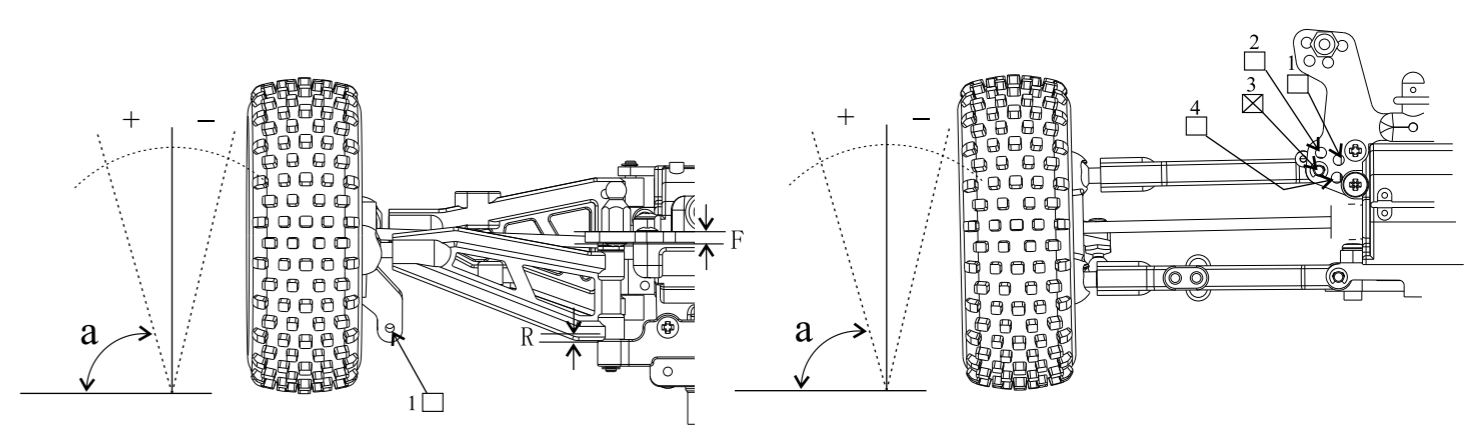

Front Adjust Ring (F) 2 mm

Rear Adjust Ring (R) 0 mm

Camber angle (a) +1°

Camber angle (a) -1°

Ground Clearance (D) 43 mm

## Rear Suspension (Off-road Buggy)

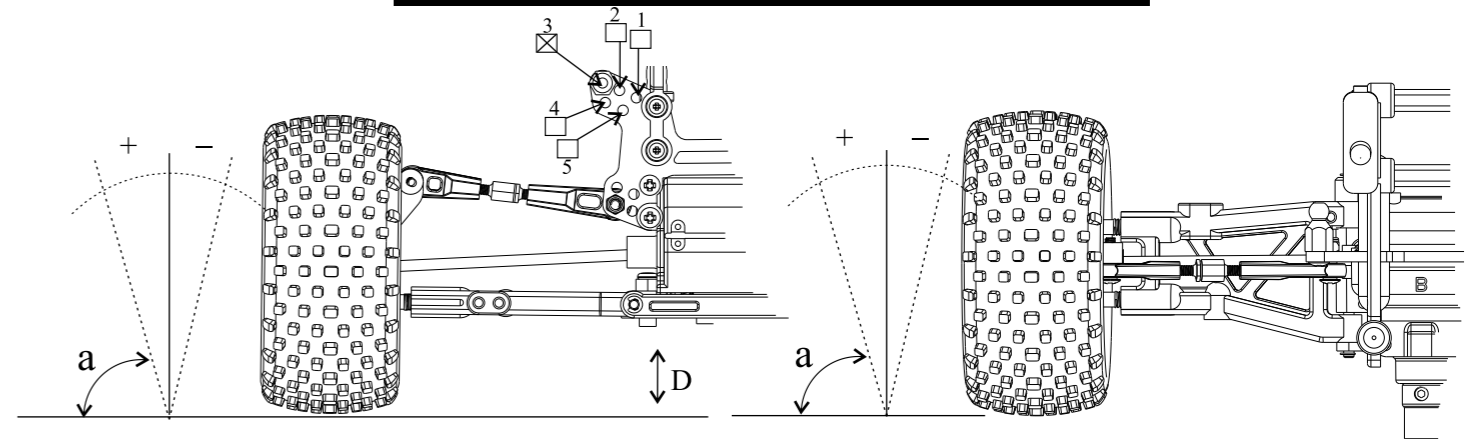

Camber angle (a) -2.5°

Ground Clearance (D) 38 mm

Camber angle (a) -2°

## Steering System (Off-road Buggy)

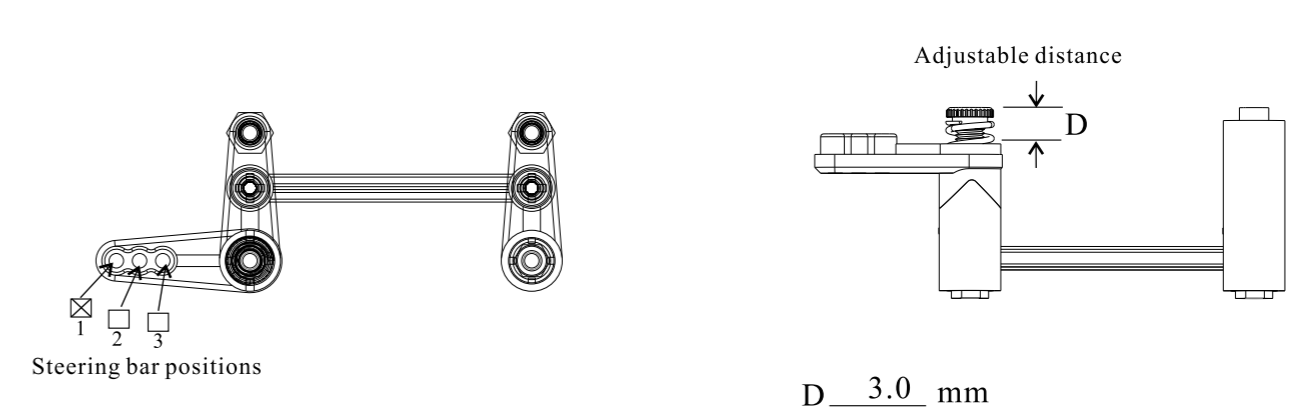

D 3.0 mm

### Steering Assembly(on-road car/off-road buggy/rally monster)-A/B1/B2

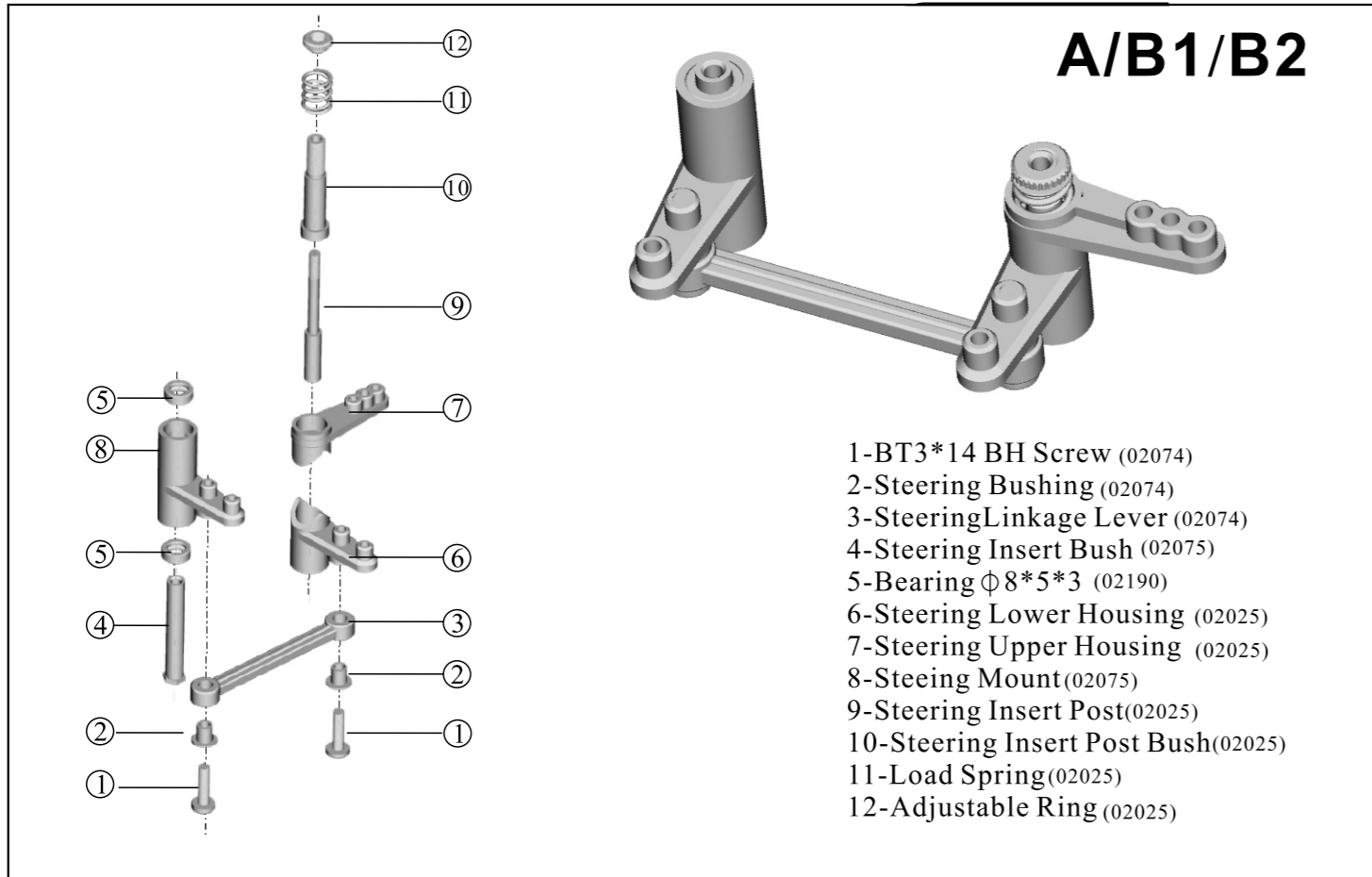

### Steering Set Assembly(monster truck)-C

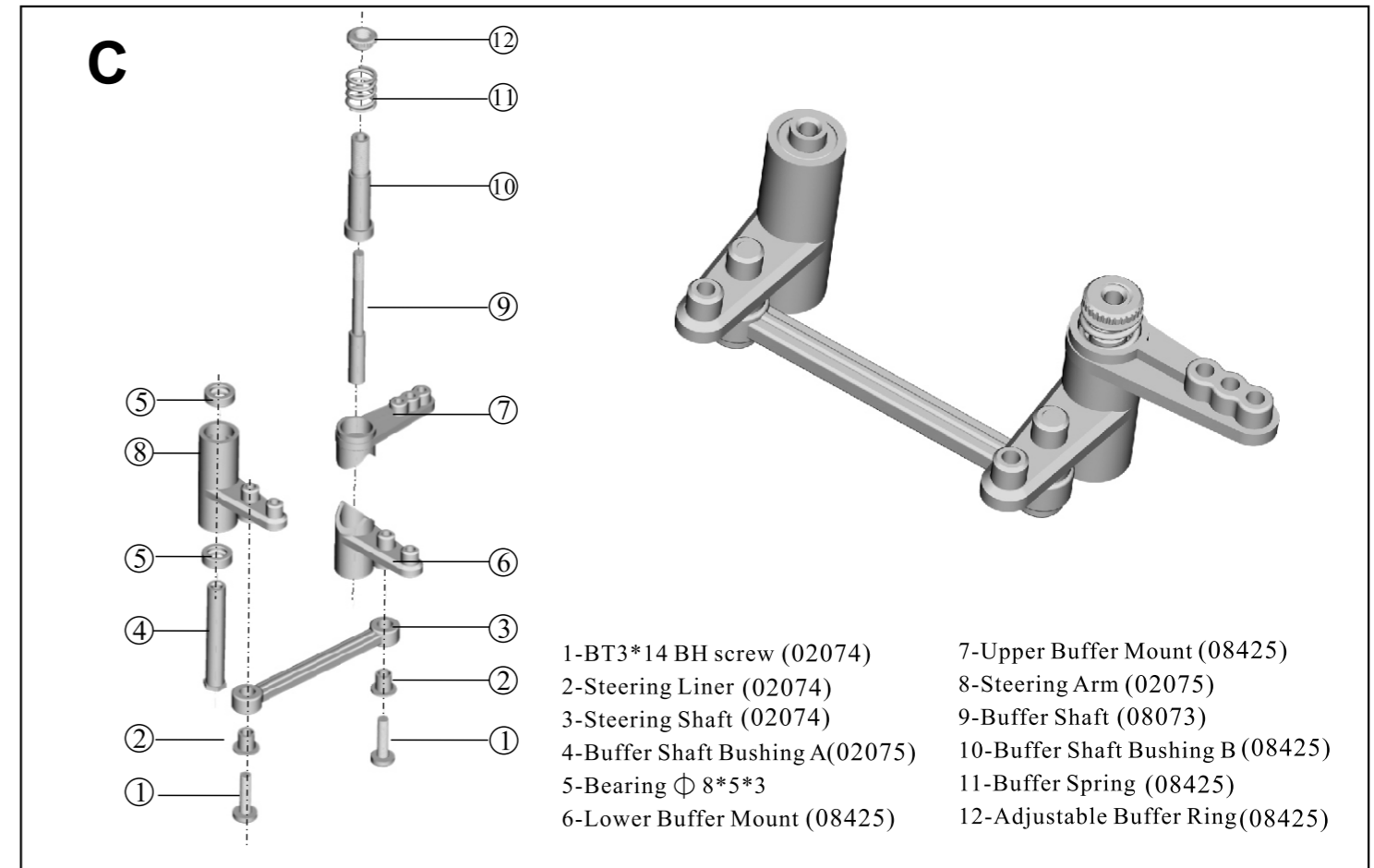

### Exhaust Pipe Assembly(on-road car/off-road buggy/rally monster/monster truck)-A/B1/B2/C

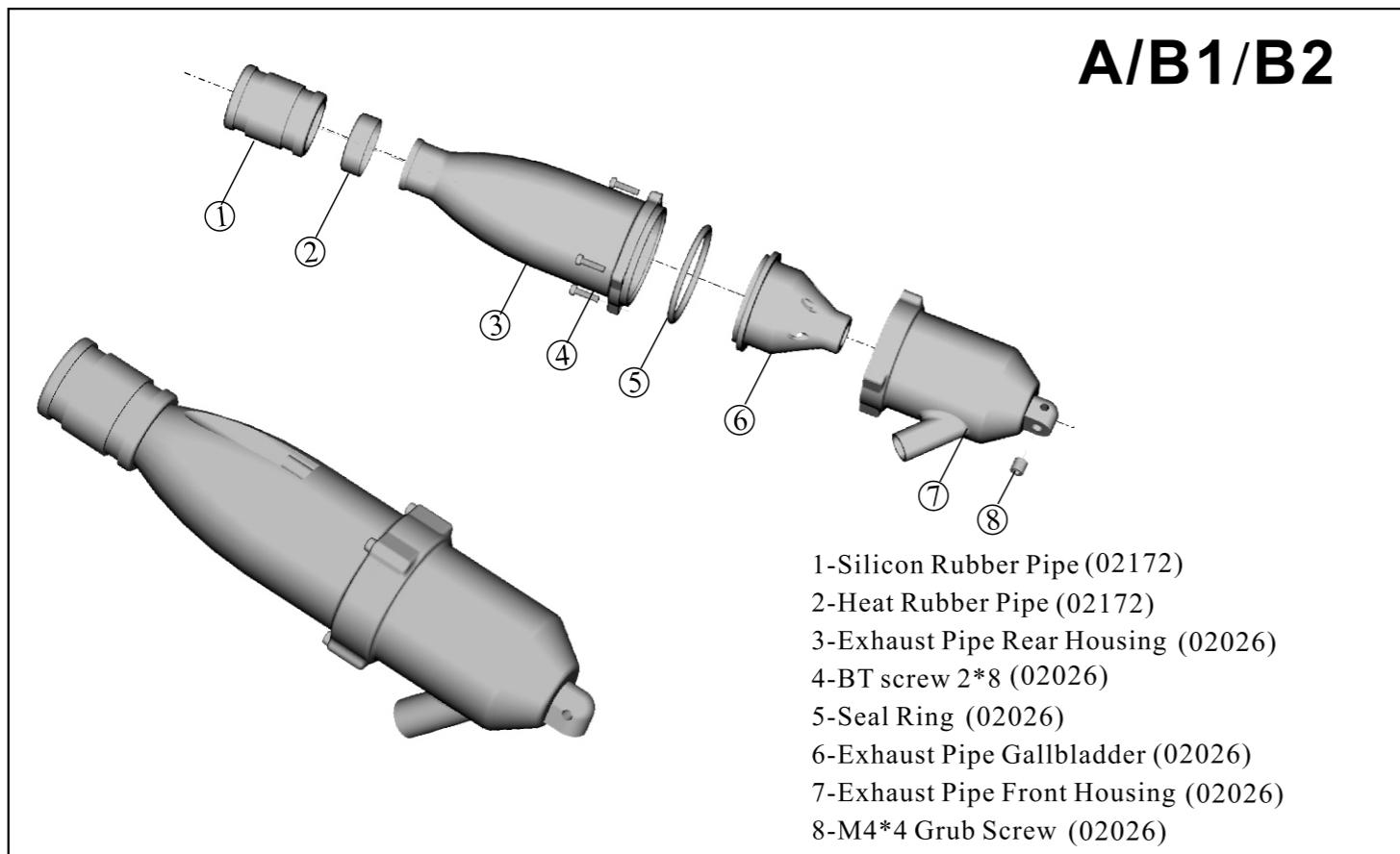

### Shock Absorber Assembly(on-road car)-A

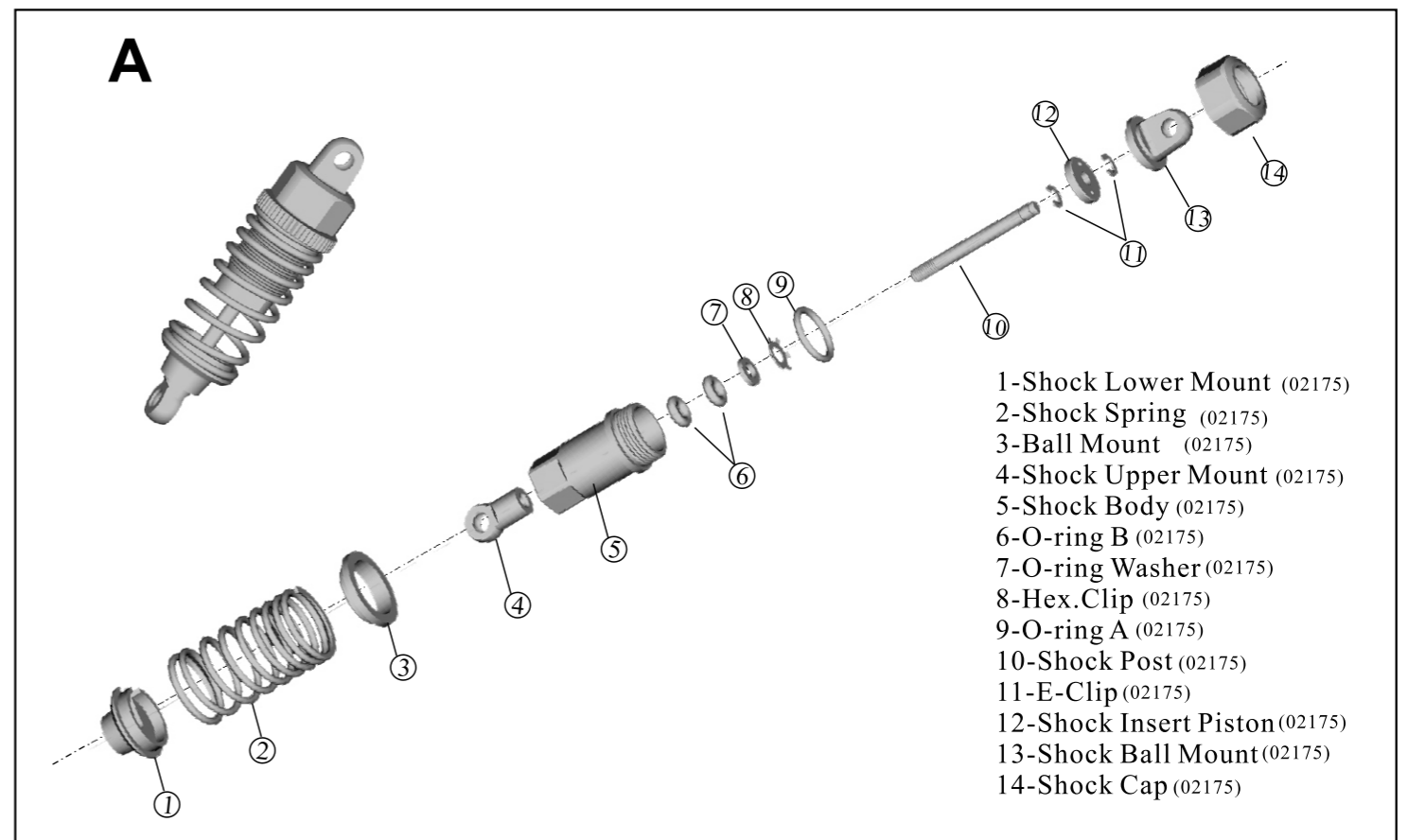

### Shock Absorber Assembly(off-road buggy/rally monster)-B1/B2

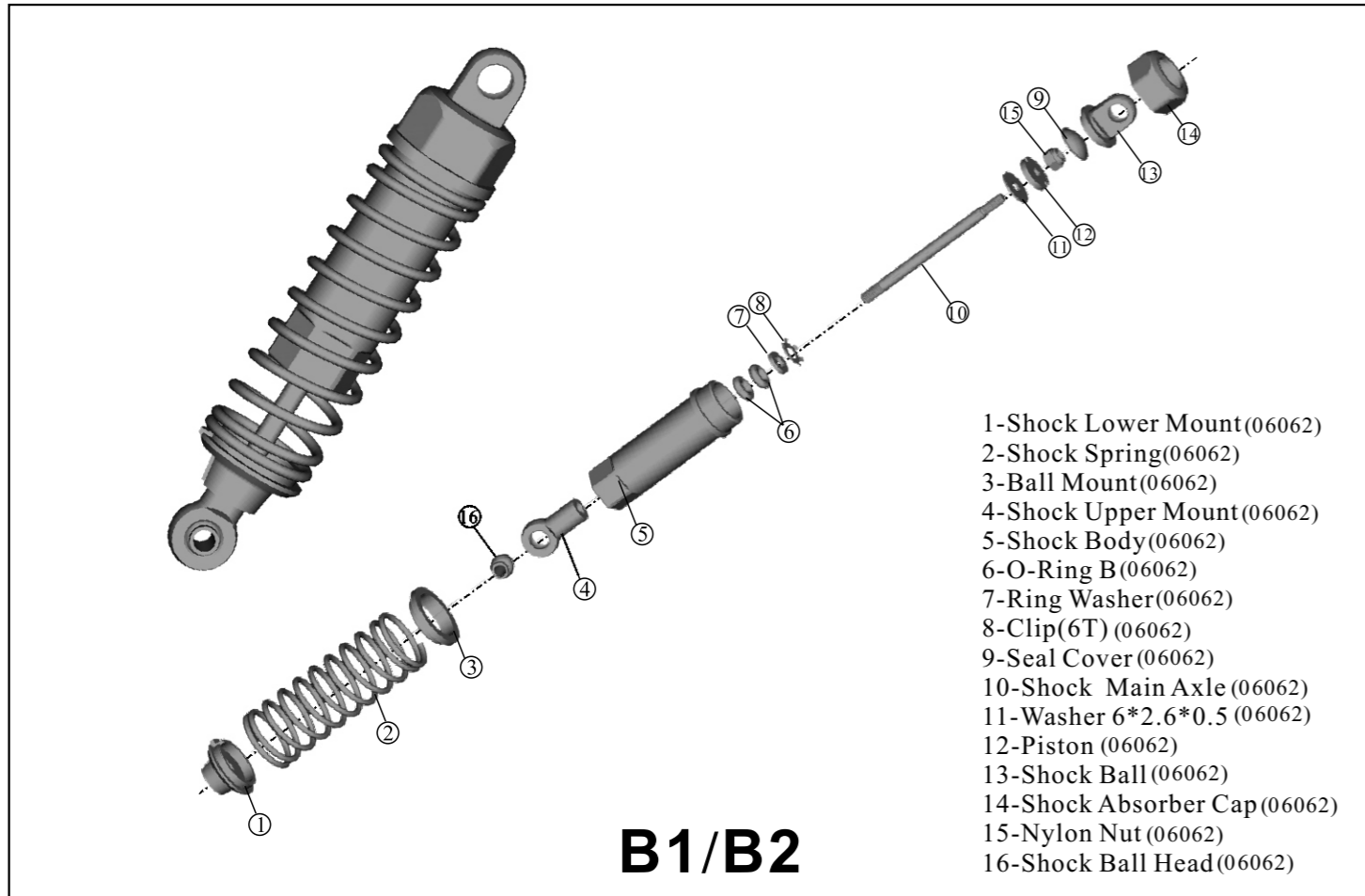

### Gear Box Assembly(on-road car/ buggy/rally monster/monster truck)-A/B1/B2/C

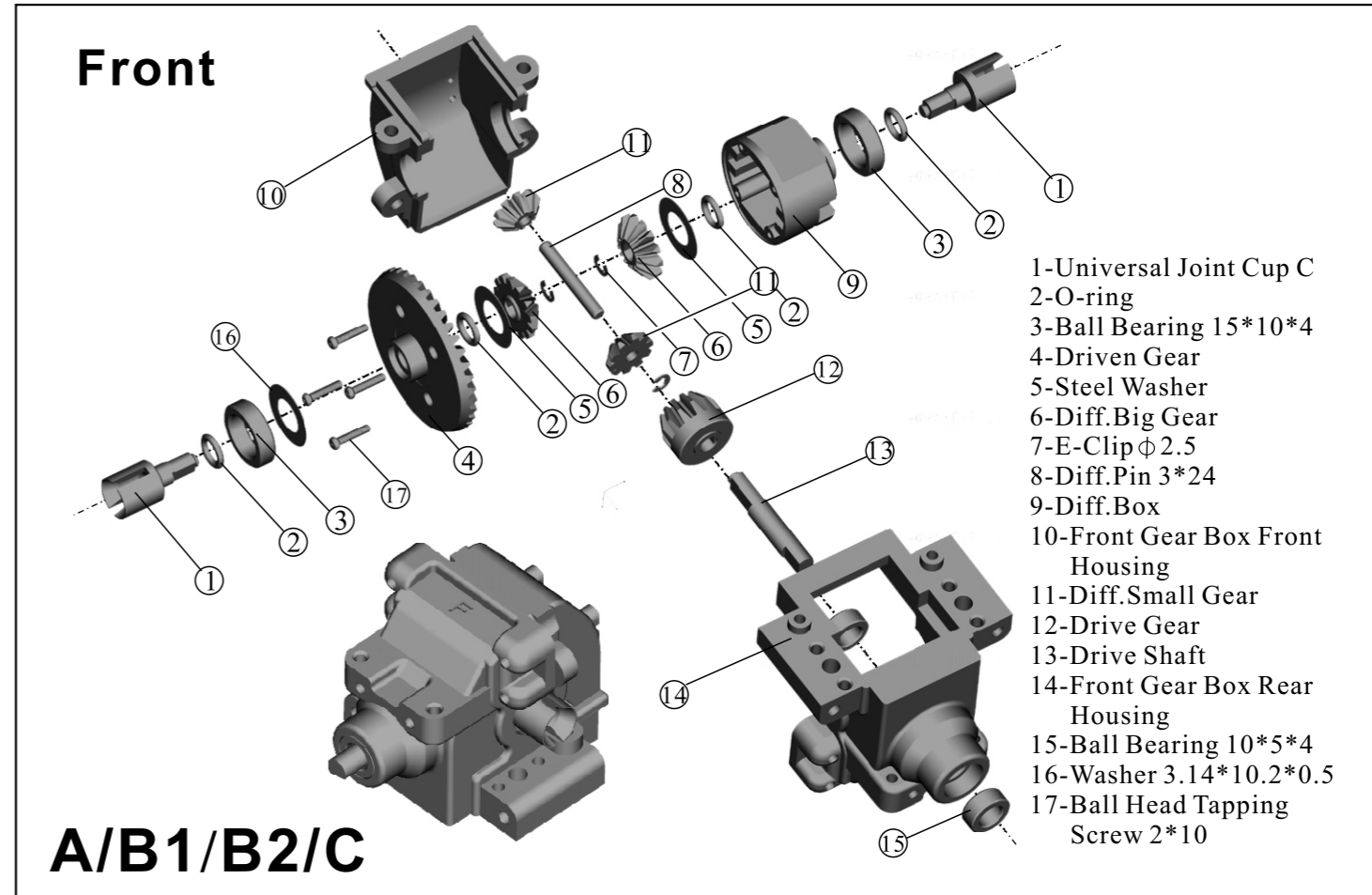

### Shock Absorber Assembly(monster truck)-C

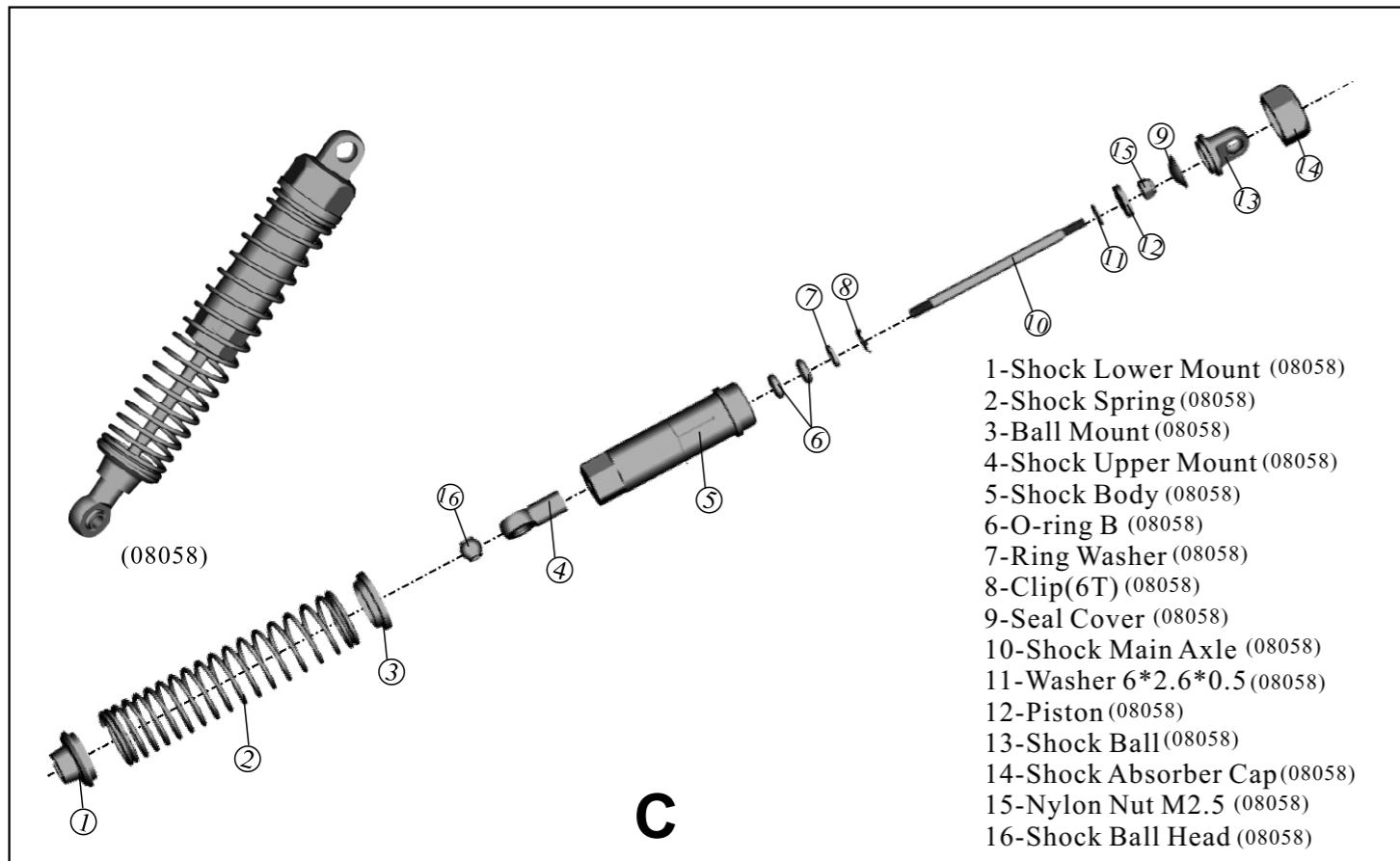

### Gear Box Assembly(on-road car/buggy/rally monster/monster truck)-A/B1/B2/C

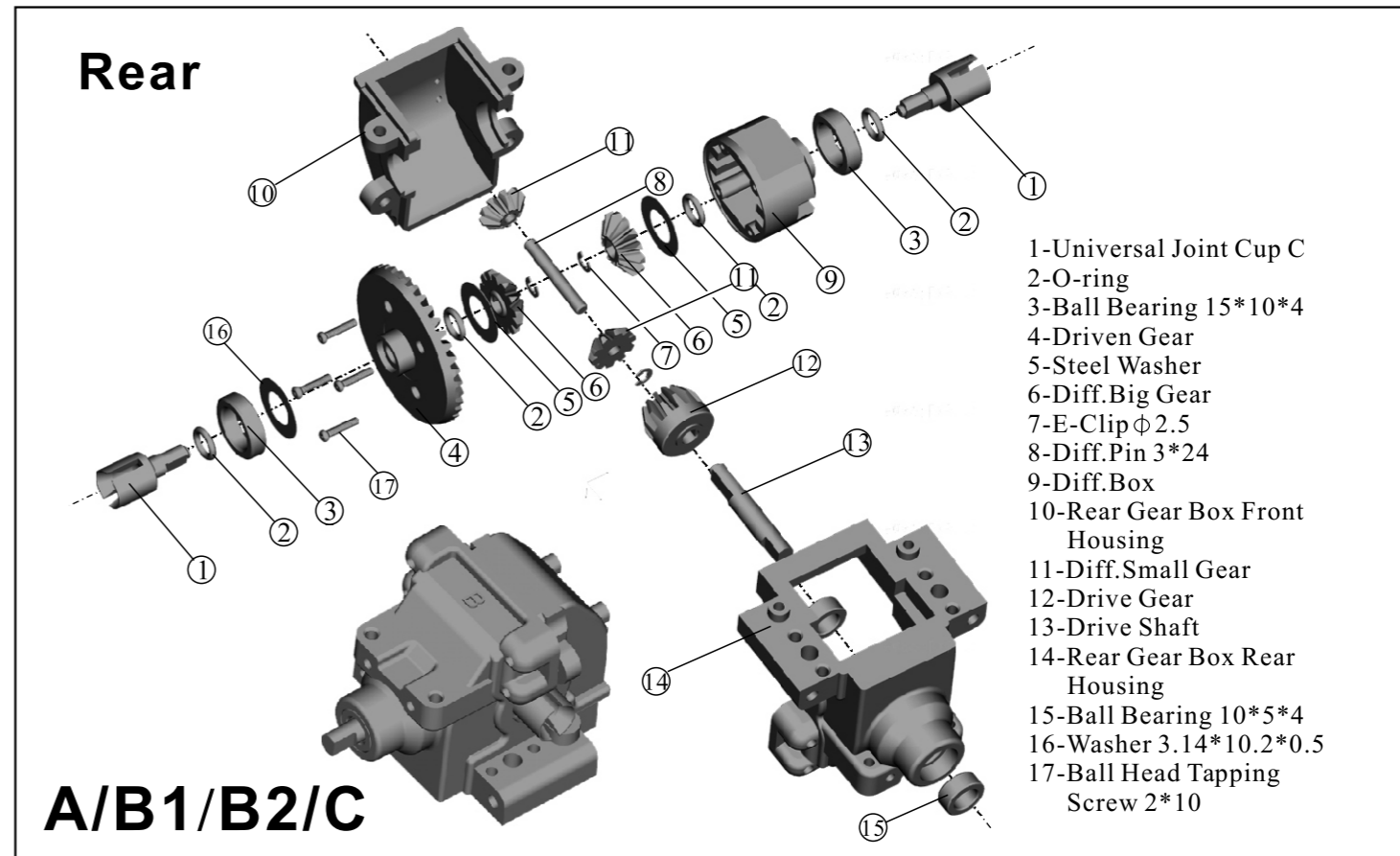



## Diff.Box Assembly(on-road car)-A

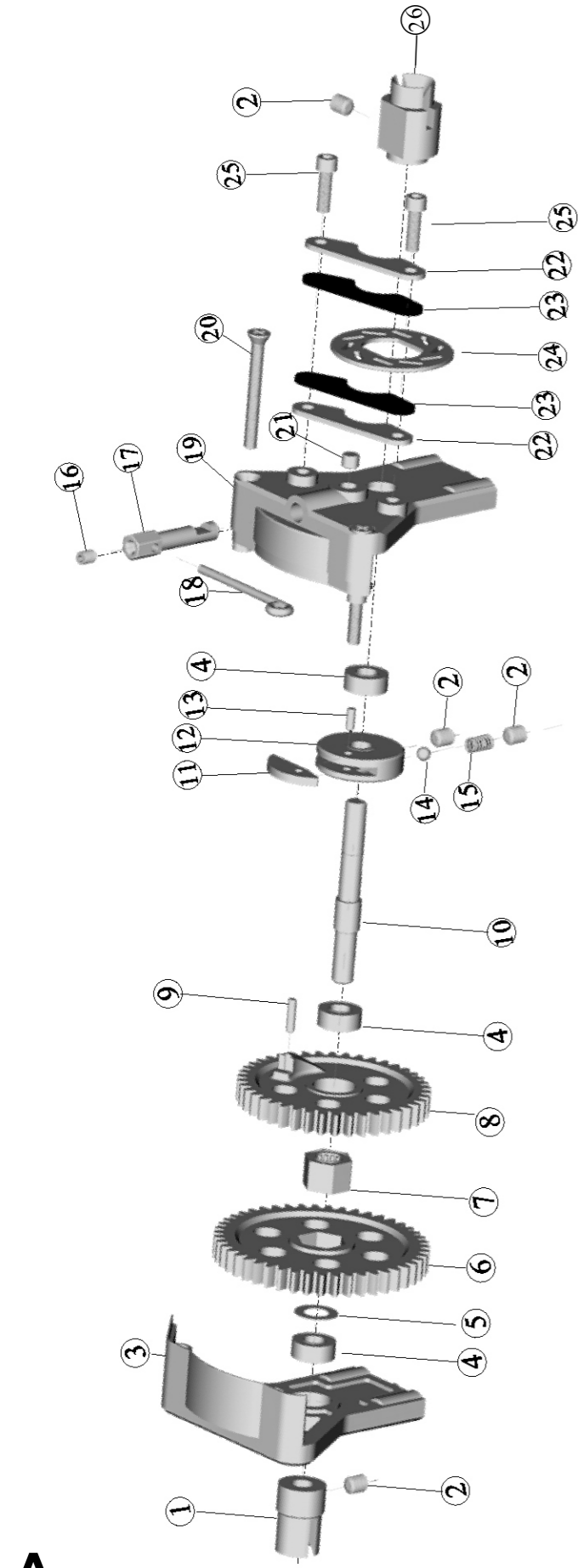

- 1-Universal Joint Cup B (02016)
- 2-Hex.Screw 4\*4 (02016)
- 3-Front Throttle Mount (02006)
- 4-Ball Bearing 10\*5\*4 (02139)
- 5-Washer (02194)
- 6-Throttle Big Gear (02040)
- 7-Hex.Bearing (02067)
- 8-Throttle Small Gear (02041)
- 9-Pin 2\*8 (02195)
- 10-2-Way Axle (02054)
- 11-Clutch Shoe(02045)
- 12-Clutch Shoe(02045)
- 13-Pin 2\*5 (02045)
- 14-Ball (02045)
- 15-2-Way Ring (02045)
- 16-Hex.Screw 3\*4 (02043)

- 17-Brake Cam (02043)
- 18-Brake Post (02043)
- 19-Throttle Rear Mount (02006)
- 20-TPE 3\*25 FH Screw (02090)
- 21-Cam Block (02043)
- 22-Brake Shoe (02044)
- 23-Lining(02044)
- 24-Brake Ring Shape Shoe(02044)
- 25-M3\*10 Cap Head Screw(02044)
- 26-Universal Joint Cup A (02034)

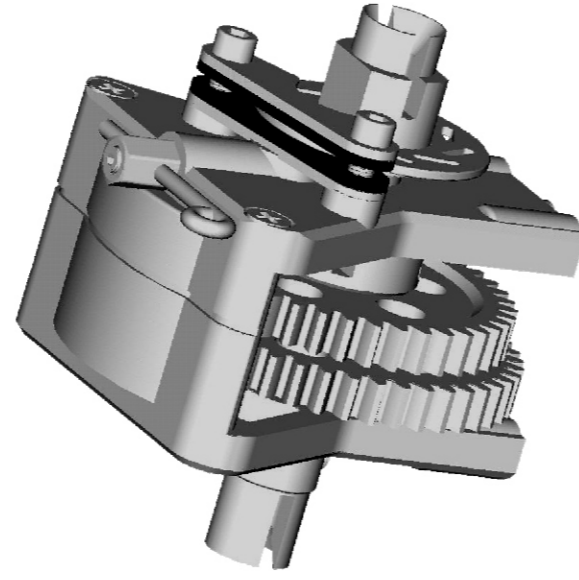

**A**

## Diff.Box Assembly(off-road buggy/rally monster)-B1/B2

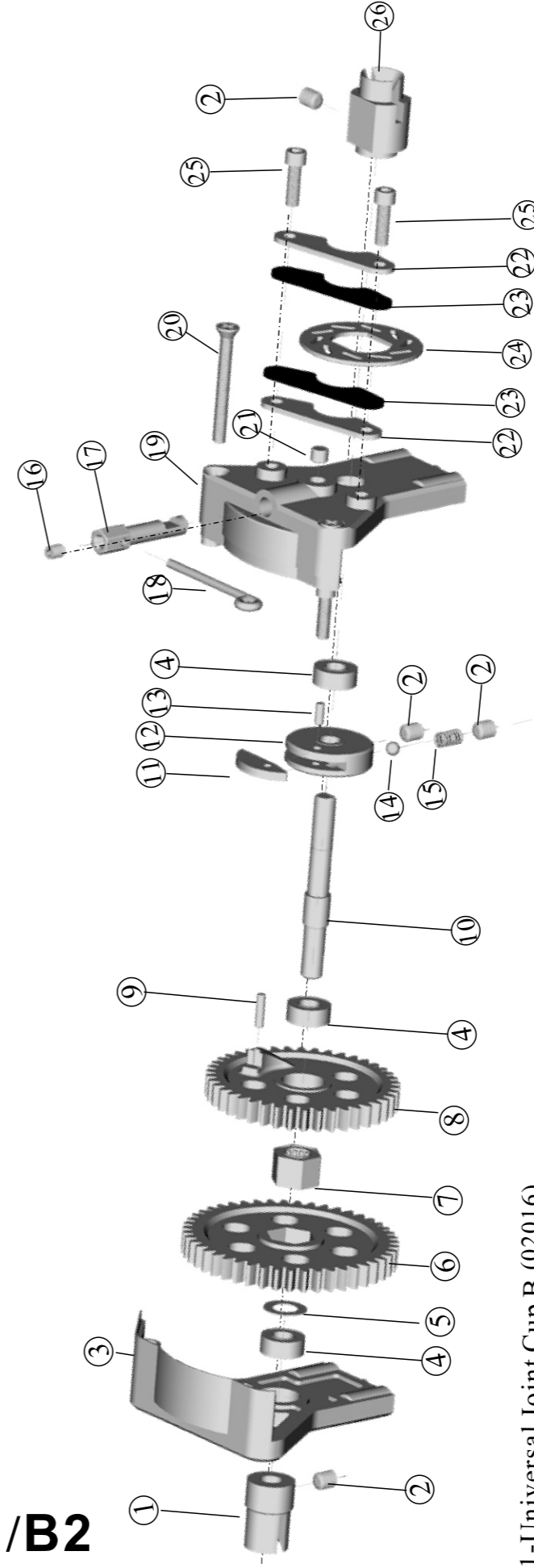

- 1-Universal Joint Cup B (02016)
- 2-Hex.Screw 4\*4 (02016)
- 3-Throttle Front Housing(02006)
- 4-Ball Bearing 10\*5\*4 (02139)
- 5-Washer (02194)
- 6-Throttle Big Gear (06032)
- 7-One-Way Hex.Bearing (02067)
- 8-Throttle Small Gear (06033)
- 9-Pin 2\*8 (02195)
- 10-2-Way Axle (02054)
- 11-Male Clutch (02045)
- 12-Female Clutch (02045)
- 13-Pin2\*5 (02045)
- 14-Steel Bead (02045)

- 15-2-Way Shift Ring (02045)
- 16-Hex.Screw 3\*4 (02043)
- 17-Brake Cam(02043)
- 18-Brake Position Hole(02043)
- 19-Throttle Rear Housing (02006)
- 20-TPE3\*25 FH Screw (02090)
- 21-Cam Set (02043)
- 22-Brake Pad (02044)
- 23-Lining Pad (02044)
- 24-Brake Ring Pad(02044)
- 25-M3\*10 Cap Screw (02044)
- 26-Universal Joint Cup A (02034)

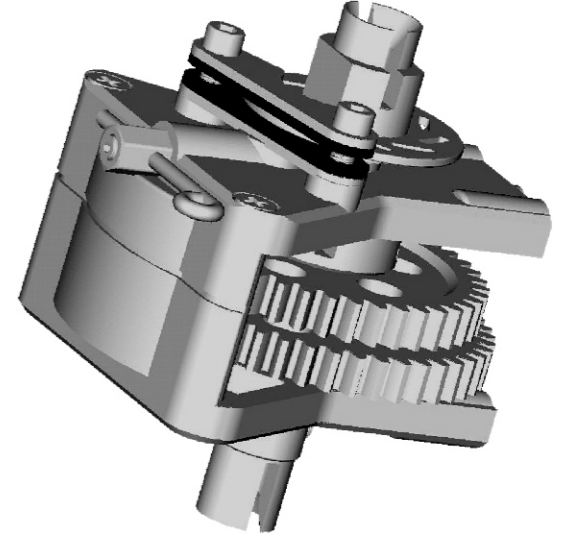

**B1/B2**

# Diff. Box Assembly(car/buggy/rally monster/monster truck)-A/B1/B2/C

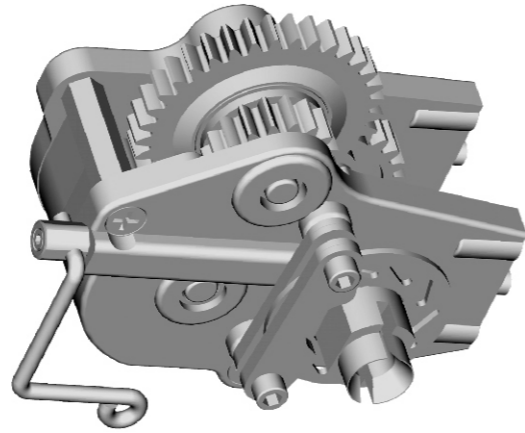
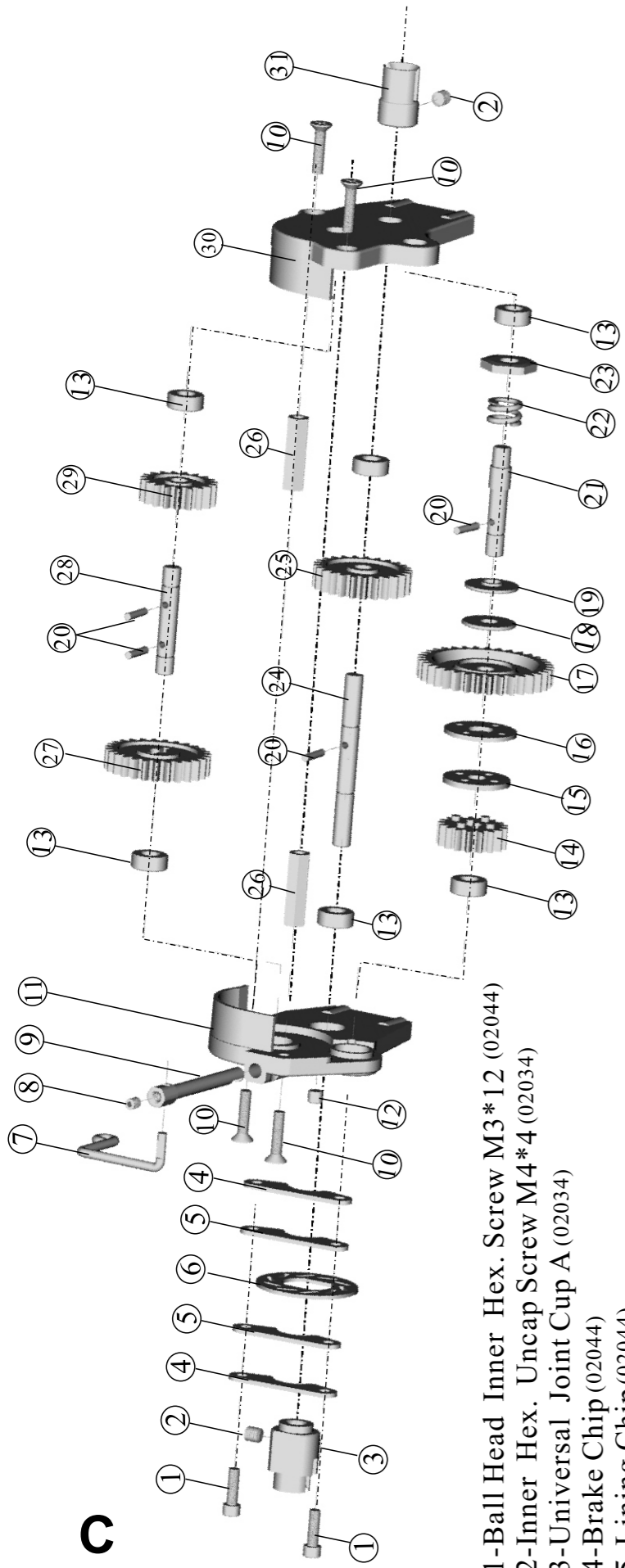





- 1-Ball Head Inner Hex. Screw M3\*12 (02044)
- 2-Inner Hex. Uncap Screw M4\*4 (02034)
- 3-Universal Joint Cup A (02034)
- 4-Brake Chip (02044)
- 5-Lining Chip (02044)
- 6-Brake Disc (02044)
- 7-Brake Lever (08016)
- 8-Inner Hex. Non-cap Screw M3\*4 (08016)
- 9-Cam Shaft (08016)
- 10-ISO M3\*4 Screw (02092)
- 11- Throttle Front Housing (08004)
- 12-Cam Assembly (08016)
- 13-Rolling Bearing 10\*5\*4 (02139)
- 14-Gear 2 (08013)
- 15-Load Resistant Chip (08013)
- 16-Load Resistant Lining (08013)
- 17-Gear 1 (08013)
- 18- Loadproof Chip (08013)
- 19- Loadproof Spring Mount (08013)
- 20-Pin 2\*10 (08013)
- 21-First Step Axle (08013)
- 22-Load Resistant Spring (08016)
- 23-Adjustable Nut (08016)
- 24-Third Step Axle (08026)
- 25-Gear (27T)
- 26- Throttle Post (08057)
- 27-Gear (35T) (08033)
- 28- Second Step Gear (08022)
- 29-Gear (17T) (08033)
- 30- Throttle Rear Housing (08004)
- 31-Universal Joint Cup B (08016)

# Car/Buggy/Rally Monster/Monster Truck(A/B1/B2/C)

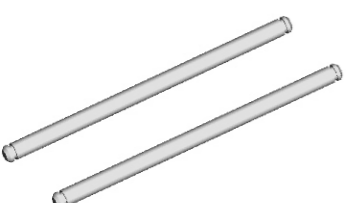
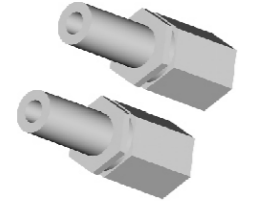
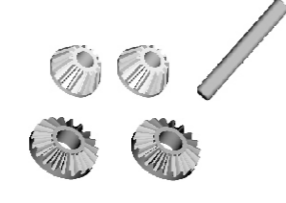
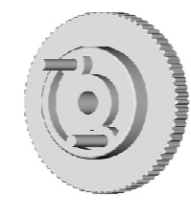
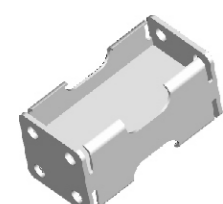

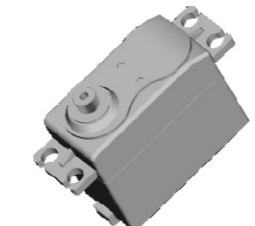
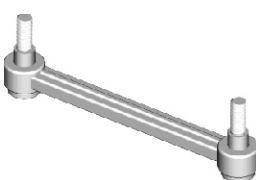
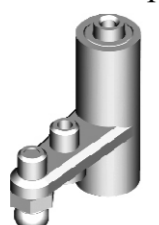
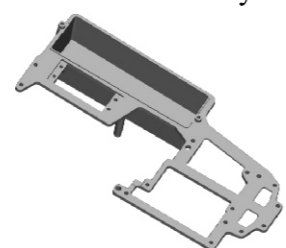
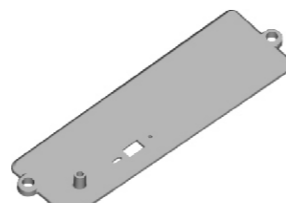
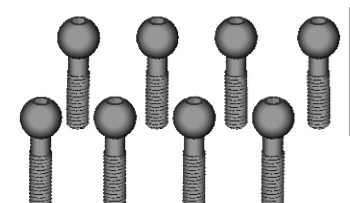
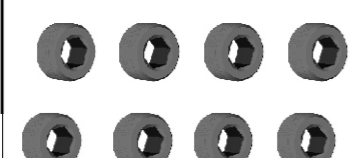
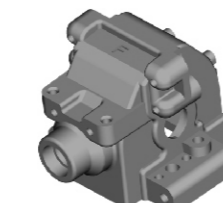
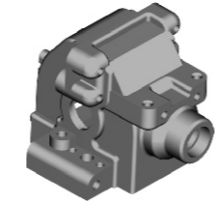
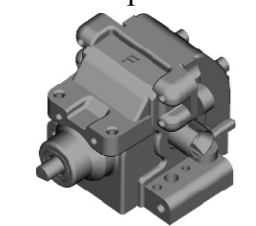
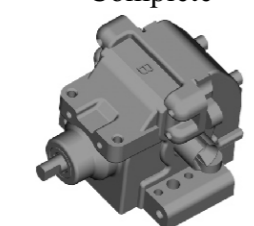

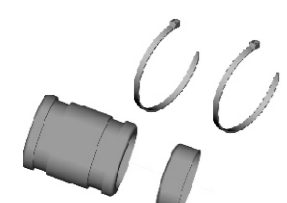
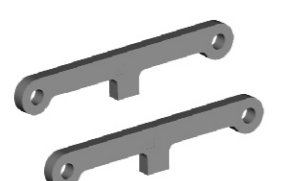
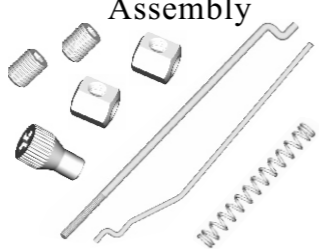
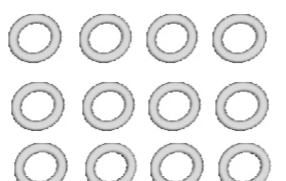





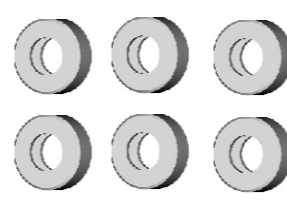
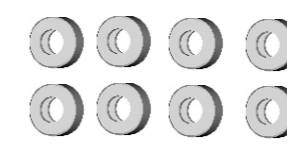
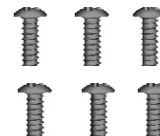
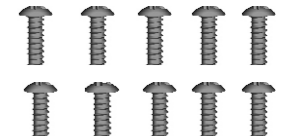
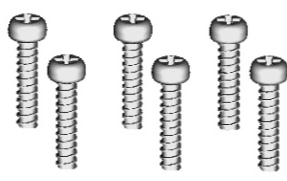

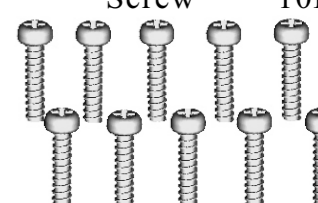
<p>02003- Front Dog bone /Centre F/R Dog bone Hole track:55mm Total length:61mm 2P</p>	<p>02004-Fuel Tank</p>	<p>02011-Handle</p>	<p>02016-Universal Joint Cup B/Set Screws 2P</p>
<p>02024-Diff. Gear Complete</p>	<p>02026-Exhaust Pipe</p>	<p>02028-Air Filter w/Sponge</p>	<p>02029-Diff.main gear</p>
<p>02030-Drive Gear</p>	<p>02031-Exhaust Manifold</p>	<p>02032-Universal Joint Cup C</p>	<p>02034-Universal Joint Cup A</p>
<p>02036-Front Lower Shaft Pin A 2P</p>	<p>02037-E-Clip 12P (Φ7. Φ4.Φ2.5.Φ2.3)</p>	<p>02039-Diff.Case (w/two rings &amp; steel washers)</p>	<p>02044- Disc Brake 2P</p>
<p>02046-Radio Tray Post A</p>	<p>02047-Radio Tray Post B</p>	<p>02048-Clutch Shoe(w/ Spring) 02048(M) 02048(F)</p>	<p>02049-Engine Holder w/Cap Head Screws</p>
<p>02055-Nylon Nut M4</p>	<p>02057-Antenna Pipe 4P</p>	<p>02058-Fuel Tube 2P</p>	<p>02060-Engine 01-12CXP(TAIWAN) 02-15CXP(TAIWAN) 03-16CXP(TAIWAN) 04-18CXP(TAIWAN) 05-16CXP(JAPAN) 06-18CXP(JAPAN)</p>

**Car/Buggy/Rally Monster/Monster Truck(A/B1/B2/C)**

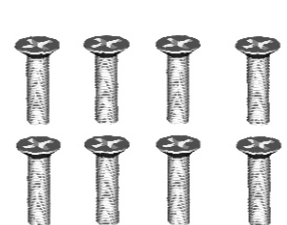
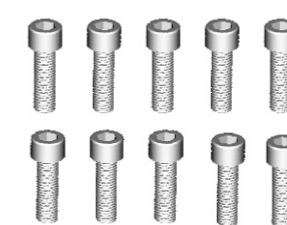
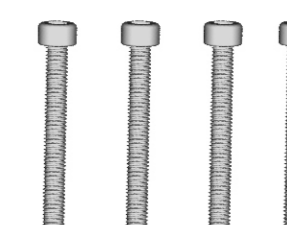
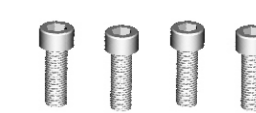
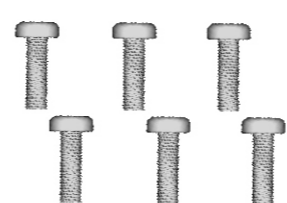
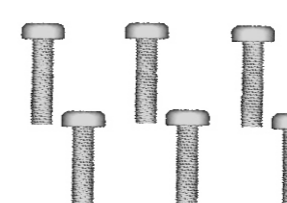
02063-Rear Lower Arm Round Pin A 2P 	02065-Flywheel Pilot Post 2P 	02066-Diff.Pinions+ Bevel Gears+Pin 	02068-Engine Flywheel 
02070-Battery Compartment 	02071-Receiver 	02072-Servo Arm 2P 	02073-Servo Unit 3kg 
02074-Steering Set Bottom Joint 	02075-Steering Arm Complete B 	02110-Radio Tray 	02111-Battery Cover 
02152-M5 Ball Head Screw 	02153-Ball Head Nut 8P 	06045-Front Gear Box Housing 	06046-Rear Gear Box Housing 
06063-Front Gear Box Complete 	06064-Rear Gear Box Complete 	02164-Ball Head Cap 8P 	02171-Sway Arm Adjuster 4P 
02172-Exhaust Pipe Tubing 	02173-Suspension Arm Pad 2P 	02174-Throttle/Brake Assembly 	02078-O-Ring 12P 

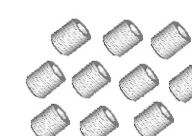

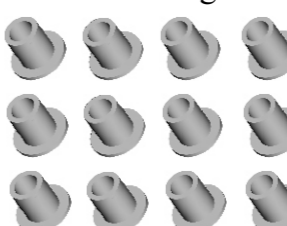







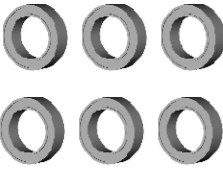
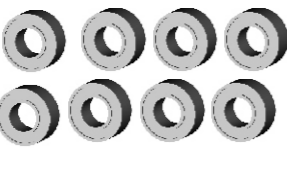

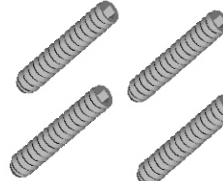
**Common parts**

**Car/Buggy/Rally Monster/Monster Truck(A/B1/B2/C)**

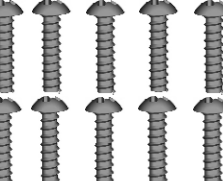

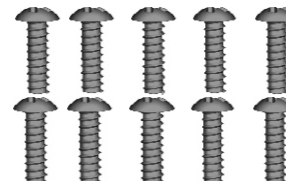

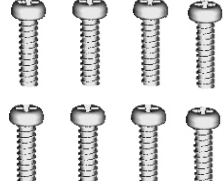
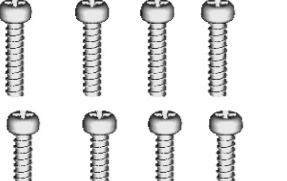
02079-Oil Bearing $\phi 15*\phi 10*4$ 6P 	02080-Oil Bearing $\phi 5*\phi 10*4$ 8P 	02081-TT3*8 BH Screw 6P 	02082-TT3*10 BH Screw 10P 
02083-BT3*12 BH Screw 6P 	02084-TT3*18 BH Screw 4P 	02085-BT2*8 BH Screw 8P 	02086-BT2*10 BH Screw 10P 
02087-TPE3*10 FH Screw 15P 	02088-TPE3*14FH Screw 13P 	02089-TPE3*15FH Screw 9P 	02090-TPE3*25FH Screw 4P 
02092-ISO 3*10 Screw 8P 	02093-M3*10 Cap Head Screw 10P 	02094-M3*28 Cap Head Screw 4P 	02095-M3*8 Cap Head Screw 4P 
02096-3*10 Cap Head Screw 6P 	02097-3*14 Cap Head Screw 6P 	02098-M3*4 Grub Hex. Screw 8P 	02099-M4*4 Grub Hex. Screw 10P 
02100-Wheel Hex. 8P 	02101-Steering Plate Bushing 12P 	02102-Nylon Nut M3 6P 	02103-Zip Tie 6P 

**Common parts**

## Car/Buggy/Rally Monster/Monster Truck(A/B1/B2/C)

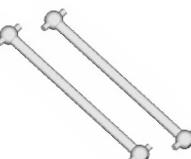
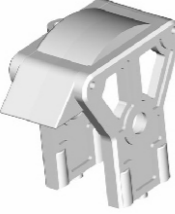



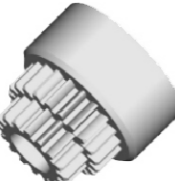
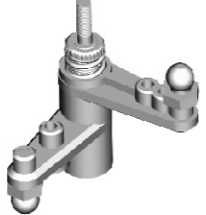
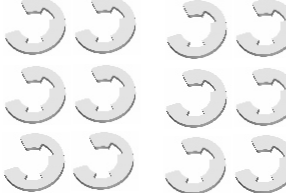





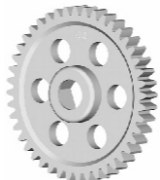
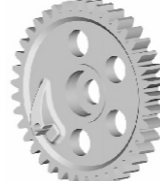
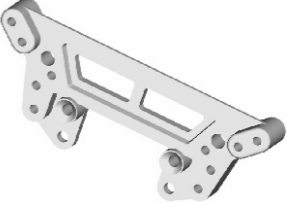
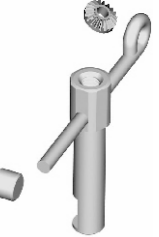

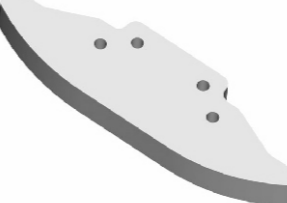

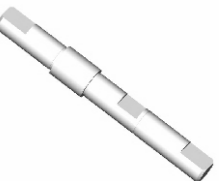

02138-Ball Bearing φ15*φ10*4 6P 	02139-Ball Bearing φ10*φ5*4 8P 	02155-Chargeable Battery Pack (6V 1100mA) 	02176-Cap Head Screw 3*12 6P 
02177- Grub Screw 4 * 8 4P 	02178- Flat Head Screw 3 * 12 10P 	02179- Flat Head Screw 3 * 14 10P 	02180- Flat Head Screw 3 * 16 10P 
02181-Cap Head Self- Tapping Screw 3*15 10P 	02183-Servo Mount 8P 	02184-Cap Head Tapping Screw 3*12 10P 	03027-Charger/Battery Wire Connector 
01293-BT 2.6*6 BH Screws 8P 	01294-BT 2.6*12 BH Screws 8P 	01295-TPE 3*20 FH Screws 8P 	

## On-road Car(A)

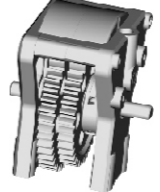
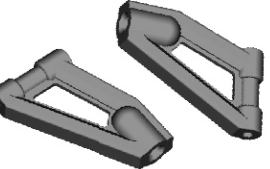
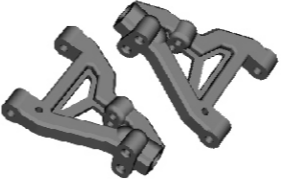
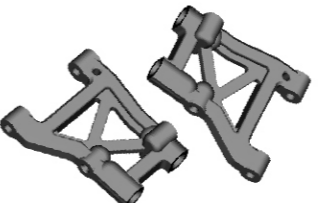
02003T-Rear Dog bone 2P Hole Track:54.5mm Total Length:60mm 	02006-Front/Rear Throttle Mount 	02009-Front Bumper Top Plate 	02010-Body Post 4pcs 
02012-Front&rear link/ steering link/Servo Link 2P 	02023-Clutch Bell (Double Gear) 	02025-Steering A 	02037-E-Clip 12 pcs (φ7. φ4.φ2.5.φ2.3) 

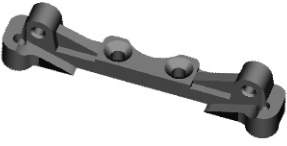
Spare parts

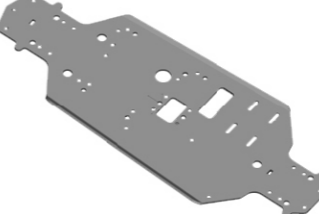
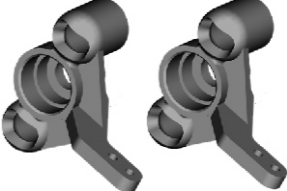
## On-road Car(A)

02040-Spur Gear (44T) 	02041-Spur Gear (39T) 	02042-Rear Shock Tower 	02043-Brake Cam 
02045-Two way Drive Clutch 	02052-Front Bumper Foam 	02053-Body Clip 8pcs 	02054-Centre Gear Shaft 
02116-On-road Touring Car Tyre 2P 	02228-Star Style Spoke Wheel Rim 2P 	02185-Wheel Complete (02116+02228) 	02064-Rear Body Post Plate 
02067-Hex.Bearing 	02076-Centre Diff. Complete 	02077-Front Bumper Holder 	02147-Front Upper Suspension Arm 
02148-Front Lower Suspension Arm 	02149-Rear Lower Suspension Arm 	02150-Rear Anti-Squat Plate 	02151-Front Upper Suspension Holder 
02162-Front Shock Tower 	02163-Chassis 	02165-Steering Hub (left/right) 	02166-Rear Wheel Hub Carrier (left/right) 





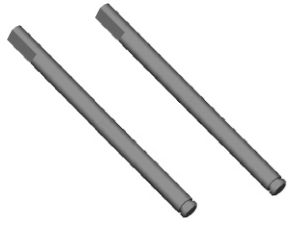
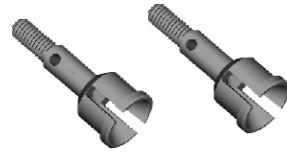
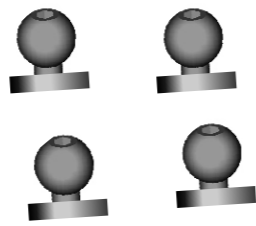
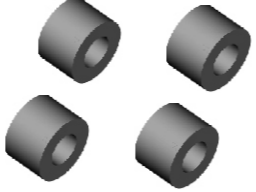
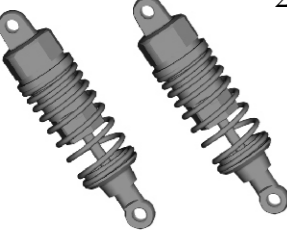



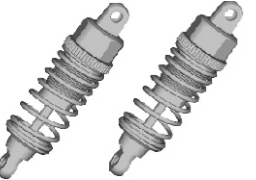
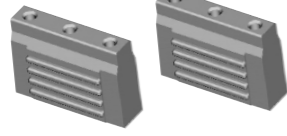

Spare parts

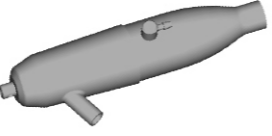
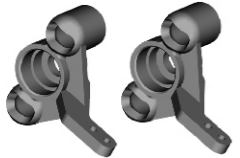
### On-road Car(A)-Spare parts

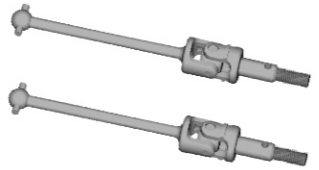
02167-Front Lower Suspension Pin A 2pcs 	02168-Wheel Axle 2P 	02169-Ball End A 4P 	02170-Ball Head Pad 4P 
02175-Shock Absorber 2P 			

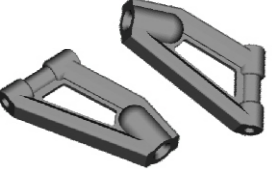
Spare parts

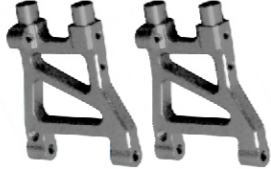
### On-road Car(A)-Upgradable parts

122004-Aluminum Shock Absorber 2P 	122005-Aluminum Engine Mount 2P 	122006-Aluminum lightweight flywheel 	122009-Aluminum Exhaust Pipe 
122011-Aluminum Steering Hub(L/R) 	122012-Aluminum Rear Hub Carrier (L/R) 	122015-Universal Drive Joint 2P 	122017-Aluminum Front/rear & Servo Link 2P 
122018-Aluminum Front Upper Arm 2P 	122019-Aluminum Front Lower Arm 2P 	122021-Aluminum Rear Lower Arm 2P 	122022-Aluminum Front Shock Tower 

### On-road Car(A)-Upgradable parts

122023-Aluminum Rear Shock Tower 	122025-Aluminum Centre Diff. Mount +Posts 	122034-Aluminum Rear Anti-Squat Plate 	122037-Aluminum Body Post 4P 
122039-Aluminum Wheel Rim 2PCS 	122040-Aluminum Ackerman Plate 	122042-Aluminum Wheel Hex. Mount 4P 	122048-Aluminum Nut M3 8P 
122049-Aluminum Nut M4 4P 	122057-Alum. Steering Servo Saver Complete 	122058-Aluminum Front Bumper Upper Plate 	122059-Aluminum Fuel Tank Cover Plate 
122064-Aluminum Battery Case Top Cover 	122065-Compact Aluminum Fuel Tank / Radio Tray 	02156-Aluminum Fuel Filter 	02031A-Polished Aluminum manifold+ Pad 
04104- Alum. Capped air filter cover Optional Use 	122237-Anodized Aluminum Servo Arms 		

# 1/10th scale On-road Car(A)-Assembly View

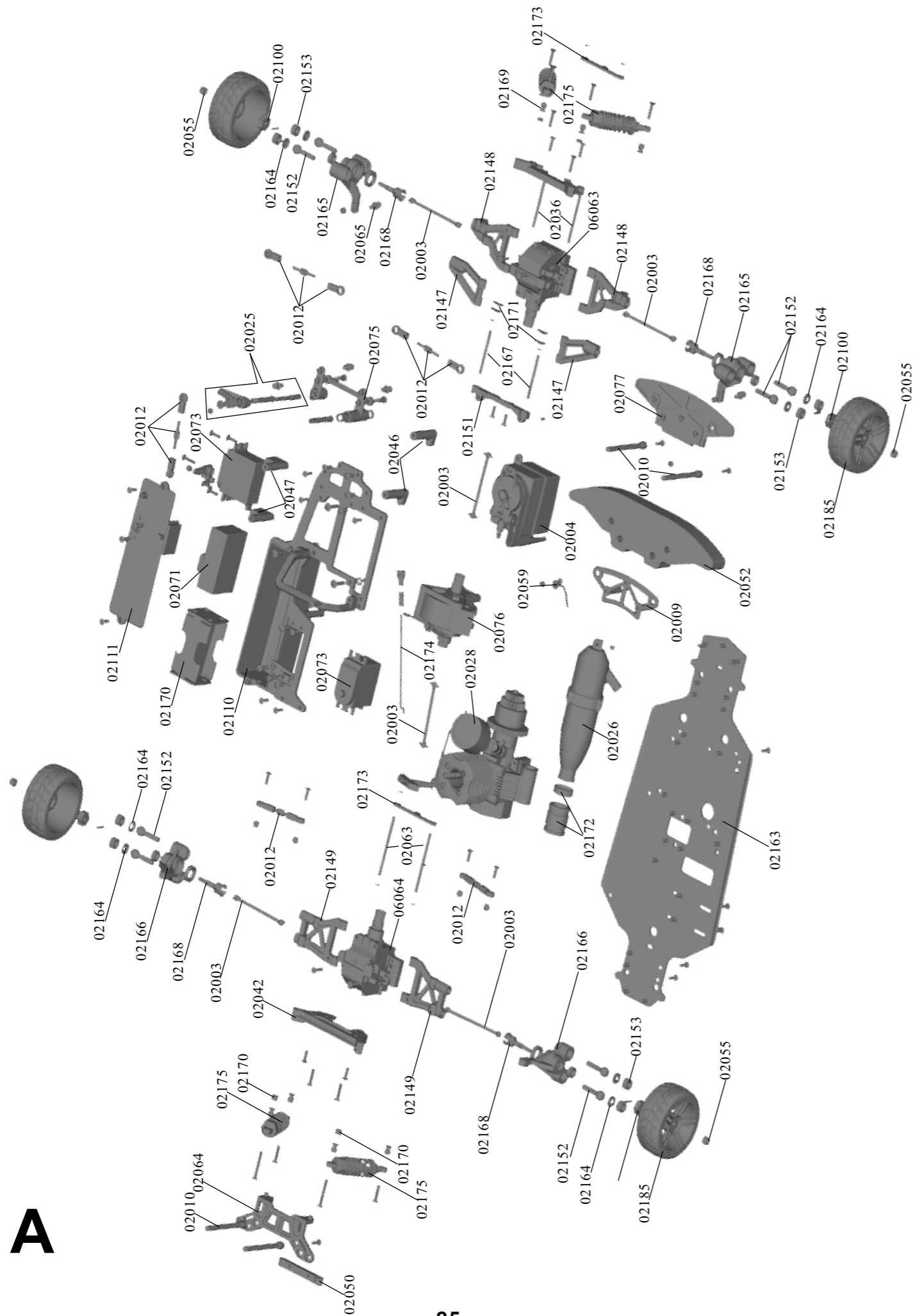

# Off-road Buggy/Rally Monster(B1/B2)

06006-Dogbone 70mm*2 	06007-Shock Ball Head 4P 	06016-Front/rear Link & Steering Servo Link 2P 	06023-Ball Head B 4P 
06033-Spur Gear(42T) 	06034-Centre Diff. Complete 	06043-Steering Hub (Left/Right) 	06044-Rear Wheel Hub Carrier (Left/Right) 
06051-Front Upper Arm 	06052-Front Lower Arm 	06053-Rear Lower Arm 	06054-Rear Anti-Squat Plate 
06055-Front Upper Arm Holder 	06056-Chassis 	06057-Tail Wing Post 	06058-Front Shock Tower 
06059-Rear Shock Tower 	06060-Front Suspension Arm Round Pin B 2P 	06061-Dogbone 84mm*2 	06062-Shock Absorber 
06102-OLD Style Off-road Spoke Rear Wheel Rim 2P 	06232-Spur Gear(47T) 	06267-One-way Hex. Bearing w/ Bearing Hex. Nut 	02006-Front/Rear Diff. Mount 

## Off-road Buggy/Rally Monster(B1/B2)

02023-Clutch Bell (Double Gear) 	02025-Steering Assembly A 	02043-Brake Cam 	02045-Two Way Drive Clutch 
02054-Centre Gear Shaft 	02110-Radio Tray 	02111-Battery Cover 	

### Off-road Buggy(B1)

Common parts

06003-Front Bumper 	06004-Front Body Post 	06009V-V- tread Off-road Buggy Front Tire 2P 	06010V-Front Wheel Complete with OLD style wheel rim and V- tread tyre 2P 
06025V-V- tread Off-road Buggy Rear Tire 2P 	06026V-Rear Wheel Complete with OLD style wheel rim and V- tread tyre 2P 	06101-OLD Style Off-road Spoke Front Wheel Rim 2P 	06017-Tail Wing Stay 2P 
06020-Tail Wing Adjustable Mount 2P 	06100-OLD Style Off-road Buggy Wing 	02168-Wheel Axle 2P 	

### Rally Monster(B2)

15503-Front Bumper Set 	15504-Rear Bumper Set 	62013-Body Post 4P 	62017-Body Post Mount(F) 2P 	62018-Body Post Mount(R) 2P 
----------------------------	---------------------------	------------------------	---------------------------------	---------------------------------

Spare parts

## Rally Monster(B2)

06024-Wheel Rims (F/R) 2P 	08059-Dogbone(F/R) 89.5mm 2P 	15506-Wheel Axle 2P 	08065-Wheel Hex. 4P 	15505-Rear Anti-Squat Plate 
15501- Tires(F/R) 2P 	15502- Wheels Complete (F/R) 2P 	06102-Wheel Rims(F/R) 2P 	62051-Ball Head Self-tapping screw (2.6*12) 4P 	

Spare parts

### Buggy/Rally Monster(B1/B2)-Upgradable parts

122005-Aluminum Engine Mount 2P 	122009-Aluminum Exhaust Pipe 	122025-Aluminum Centre Diff. Mount +Posts 	122040-Aluminum Ackerman Plate 	122042-Aluminum Wheel Hex. Mount 4P 
<b>OLD NO.:02128B</b>	<b>OLD NO.:02124</b>		166015-Universal Drive Joint 2P 	<b>OLD NO.:02134B</b>
122048-Aluminum Nut M3 8P 	122049-Aluminum Nut M4 4P 	122057-Alum. Steering Servo Saver Complete 	122059-Aluminum Fuel Tank Cover 	122006-Aluminum lightweight flywheel 
<b>OLD NO.:02191B</b>	<b>OLD NO.:02190B</b>			
122064-Aluminum Battery Case Top Cover 	166004-Aluminum Shock Absorber 2P 	166011-Aluminum Steering Hubs(L/R) 	166012-Aluminum Rear Hub Carrier (L/R) 	166017-Aluminum Front/rear & Servo Link 2P 
	<b>OLD NO.:06038</b>	<b>OLD NO.:06066</b>	<b>OLD NO.:06067</b>	<b>OLD NO.:06048B</b>
166018-Aluminum Front Upper Arm 2P 	166019-Aluminum Front Lower Arm 2P 	166021-Aluminum Rear Lower Arm 2P 	166022-Aluminum Front Shock Tower 	166023-Aluminum Rear Shock Tower 
<b>OLD NO.:06039B</b>	<b>OLD NO.:06040B</b>	<b>OLD NO.:06042B</b>	<b>OLD NO.:06036B</b>	<b>OLD NO.:06037B</b>
166044-Aluminum Wing Stay 	166045-Aluminum Wing Adjustable Mount 	188065-Compact Aluminum Fuel Tank/ Radio Tray 	02031A-Polished Aluminum manifold+ Pad 	04104- Alum.Capped air filter cover Optional Use 
			02156-Aluminum Fuel Filter 	122237-Anodized Aluminum Servo Arms 
				<b>OLD NO.:80237</b>





## Monster Truck(C)

02107-Clutch Bell (single gear) 	02165-Steering Hub (Left/Right) 	02166-Rear Wheel Hub Carrier (Left/Right) 	06007-Shock Ball Head 4P 
06016-Servo Link 2P 	06055-Front Upper Arm Holder 	06056-Chassis 	08002-Front Bumper 
08004-Front/Rear Diff. Mount 	08007-Body Post 4P 	08012-Shock Tower 	08013-Diff. Gear Complete 
08016-Brake Cam Mount 	08017-Adjustable Nut 	08018-First Step Axle 	08021-Shock Ball Head 1 
08022-Second Step Axle 	08026-Third Step Axle 	08027-Pin 2*10 10P 	08028-Front Bumper Post 4P 
08030-Front Shock Tower Holder 	08031-Rear Shock Tower Holder 	08032-Bumper Spring 4P 	08033-Diff. Gear 1(35T) /2(17T) 

Spare parts

## Monster Truck/(C)-Spare parts

08034-Brake Pads 	08042-Front/rear Link 2P 	08043-Tire 2P 	08008-Wheel Rim 2P 
08071-Wheel Complete 2P (wheel rim 08008 +Tyre 08043) 	08048-Front Upper Arm 2P 	08049-Front Lower Arm 2P 	08050-Rear Lower Arm 2P 
08051-Rear Upper Arm 2P 	08057-Diff. Post 2P 	08058- Shock Absorber 2P 	08059-Dogbone 88mm 2P 
08060-Dogbone 77mm 2P 	08061-Dogbone 63mm 2P 	08062- Rear Bumper 	08063- Diff. Gear Complete 
08064-Wheel Axle 2P 	08065-Wheel Hex. 4P 	08067- Diff. Gear 4(17T)/5(27T) 	08068-Rear Lower Arm Round Pin B 2pcs 
08069-Front Lower Arm Round Pin B 2pcs 	08072-Shock Ball Head 2 	08425-Steering Assembly A 	08152-Tire Insert Sponge 2P 

## Monster Truck(C)

12101-jeep Body (clarity) 	11601-army Body (clarity) 	11701-wecker Body (clarity) 		
--	---	---	--	--

Spare parts

## Monster Truck(C)-Upgradable parts





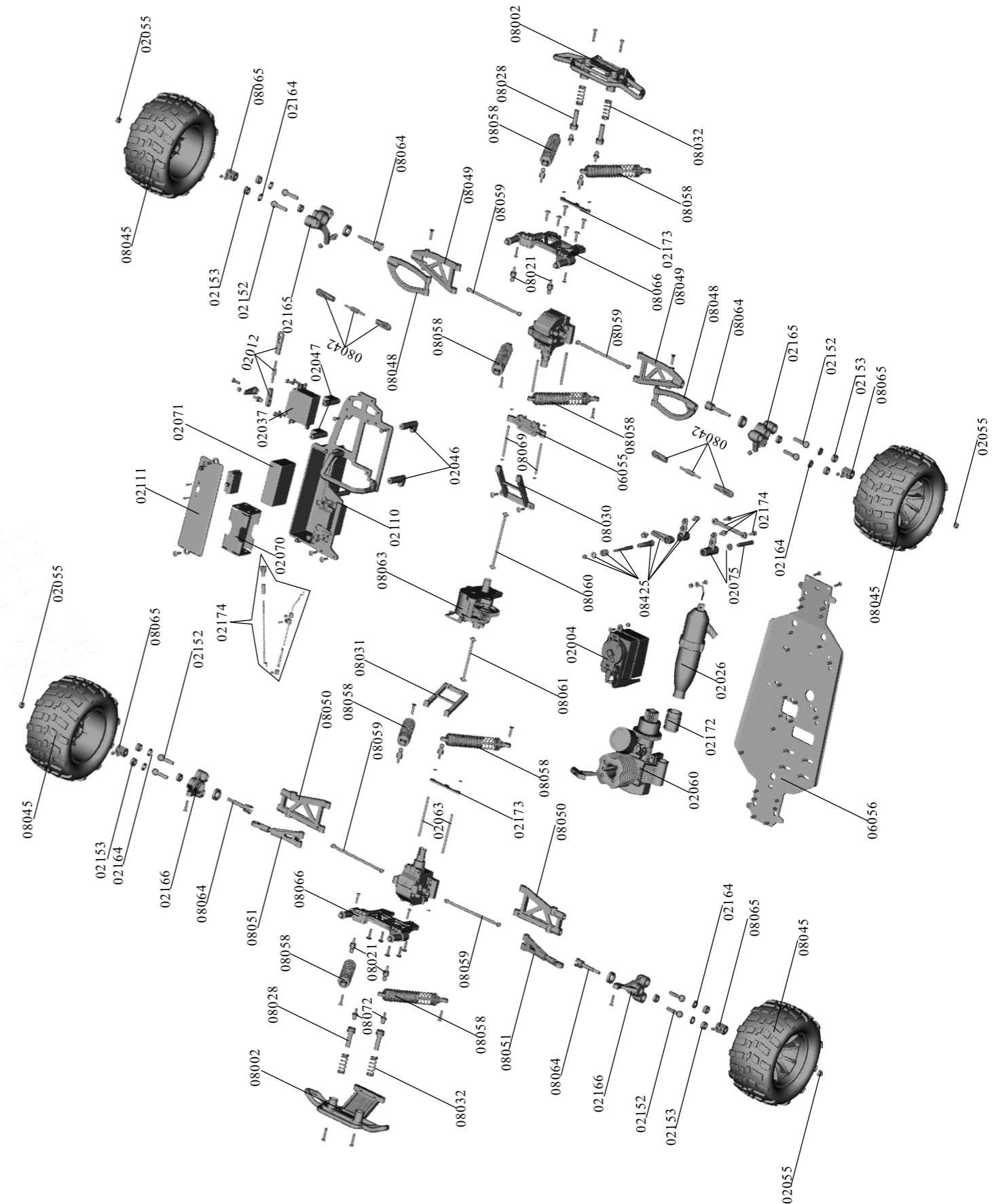





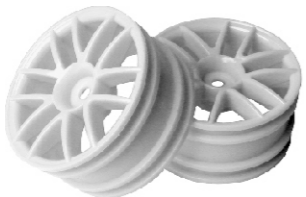







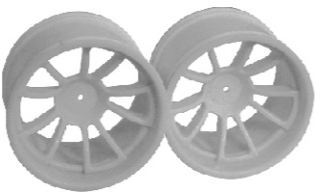

122005-Aluminum Engine Mount 2P  <b>OLD NO.:02128B</b>	122006-Aluminum lightweight flywheel 	122009-Aluminum Exhaust Pipe  <b>OLD NO.:02124</b>	122011-Aluminum Steering Hub(L/R)  <b>OLD NO.:02186</b>	122012-Aluminum Rear Hub Carrier (L/R)  <b>OLD NO.:02187</b>
122040-Aluminum Ackerman Plate 	122042-Aluminum Wheel Hex. Mount 4P  <b>OLD NO.:02134B</b>	122048-Aluminum Nut M3 8P  <b>OLD NO.:02191B</b>	122049-Aluminum Nut M4 4P  <b>OLD NO.:02190B</b>	122057-Alum. Steering Servo Saver Complete 
122059-Aluminum Fuel Tank Cover 	122064-Aluminum Battery Case Top Cover 	166017-Aluminum Front/rear & Servo Link 2P  <b>OLD NO.:06048B</b>	108004-Aluminum Shock Absorber 2P  <b>OLD NO.:08041</b>	188015-Universal Drive Joint 2P 
188018-Aluminum Front Upper Arm 2P  <b>OLD NO.:08036B</b>	188019-Aluminum Front Lower Arm 2P  <b>OLD NO.:08037B</b>	188020-Aluminum Rear upper Arm 2P  <b>OLD NO.:08070B</b>	188021-Aluminum Rear Lower Arm 2P  <b>OLD NO.:08039B</b>	108022-Aluminum Shock Tower  <b>OLD NO.:08054</b>
188031-Aluminum Front Upper Arm Mount  <b>OLD NO.:08040B</b>	188037-Aluminum Body Post 4P  <b>OLD NO.:08047B</b>	188065-Compact Aluminum Radio / Fuel Tank Tray 	02031A-Polished Aluminum manifold+ Pad 	02156-Aluminum Fuel Filter 
188039B-Aluminum Wheel Rim 2PCS 	04104- Alum. Capped air filter cover Optional Use 	122237-Anodized Aluminum Servo Arms  <b>OLD NO.:80237</b>		

## 1/10th scale Monster Truck(C)-Assembly View



C

## Wheel rims/Tyres(Optional)

<p>02113-Wheel Rim 2P</p>  <p><b>A</b></p>	<p>02018-Wheel Rim 2P</p>  <p><b>A</b></p>	<p>02018N-Wheel Rim 2P</p>  <p><b>A</b></p>	<p>02228-Wheel Rim 2P</p>  <p><b>A</b></p>
<p>06030-Wheel Rim(Front) 2P</p>  <p><b>B1</b></p>	<p>06031-Wheel Rim(Rear) 2P</p>  <p><b>B1</b></p>	<p>06008-Wheel Rim(Front) 2P</p>  <p><b>B1</b></p>	<p>06024-Wheel Rim(Rear) 2P</p>  <p><b>B1/B2</b></p>
<p>06101-Wheel Rim(Front) 2P</p>  <p><b>B1</b></p>	<p>06102-Wheel Rim(Rear) 2P</p>  <p><b>B1/B2</b></p>	<p>08008-Wheel Rim 2P</p>  <p><b>C</b></p>	<p>08008N-Wheel Rim 2P</p>  <p><b>C</b></p>
<p>02019-Tire 2P</p>  <p><b>A</b></p>	<p>02116-Tire 2P</p>  <p><b>A</b></p>	<p>06009-Tire(Front) 2P</p>  <p><b>B1</b></p>	<p>06025-Tire(Rear) 2P</p>  <p><b>B1</b></p>
<p>06009V-Tire(Front) 2P</p>  <p><b>B1</b></p>	<p>06025V-Tire(Rear) 2P</p>  <p><b>B1</b></p>	<p>15501-Tire 2P</p>  <p><b>B2</b></p>	<p>08009-Tire 2P</p>  <p><b>C</b></p>
<p>08009N-Tire 2P</p>  <p><b>C</b></p>	<p>08043-Tire 2P</p>  <p><b>C</b></p>		

We offer other different style wheel rims and tyres for your Option!